

**Instruction Manual
Model 197
Autoranging Microvolt DMM**

©Keithley Instruments, Inc.
Cleveland, Ohio, U.S.A.
Document Number 197-901-01

SPECIFICATIONS

DC VOLTS

RANGE	RESOLUTION	INPUT RESISTANCE	ACCURACY **	
			± (%rdg + counts)	
			24 Hr., * 22°-24°C	1 Yr., 18°-28°C
200mV	1 μV	>1GΩ	0.007+2	0.016+3
2 V	10 μV	>1GΩ	0.005+2	0.011+2
20 V	100 μV	11MΩ	0.006+2	0.015+2
200 V	1mV	10MΩ	0.006+2	0.015+2
1000 V	10mV	10MΩ	0.007+2	0.015+2

*Relative to calibration accuracy. **When properly zeroed.

NMRR: Greater than 60dB at 50Hz, 60Hz ±0.1%.

MAXIMUM ALLOWABLE INPUT: 1000V dc or peak ac (less than 10 seconds per minute on the 200mV and 2V ranges; 300V rms continuous).

SETTLING TIME: 1 second to within 3 counts of final reading on range.

dB MODE (ref: 600Ω): Accuracy: ±(0.02dB+1 count) above -78dBm. Resolution: 0.01dB above 0.5% of range.

TRMS AC VOLTS

RANGE	ACCURACY (1 Yr.)				
	18°-28°C ± (%rdg + counts)				
	20Hz - 50Hz*	50Hz - 10kHz*	10kHz - 20kHz*	20kHz - 50kHz**	50kHz - 100kHz**
200mV	1.00+100	0.35+100	0.6+200	1.5+250	5+400
2V - 200V	1.00+100	0.35+100	0.6+200	1.5+250	3+400
750V	1.25+100	0.75+100	1.0+200	1.8+250	3+400

*Above 1800 counts. **Above 18000 counts.

MAXIMUM ALLOWABLE INPUT: 750V rms, 1000V peak (less than 10 seconds per minute on 200mV and 2V ranges; 300V rms continuous). 10°V•Hz maximum.

3dB BANDWIDTH: 300kHz typical.

INPUT IMPEDANCE: 1MΩ paralleled by less than 75pF on 200V and 750V ranges. 1.1MΩ paralleled by 75pF on 200mV, 2V and 20V ranges. Capacitively coupled.

SETTLING TIME: 1 second to within 0.1% of final reading on range.

dB MODE (ref: 600Ω):

RANGE	INPUT	ACCURACY (±dBm)			
		18°-28°C			
		20Hz - 10kHz	10kHz - 20kHz	50kHz	100kHz
2V - 750V	200mV to 750 V (-12 to 59.8dBm)	0.18	0.18	0.28	0.50
200mV	20mV to 200mV (-32 to -12dBm)	0.18	0.18	0.28	0.65
	2mV to 20mV (-52 to -32dBm)	0.85	1.10	2.00	—
	1mV to 2mV (-58 to -52dBm)	2.00	3.00	—	—

RESOLUTION: 0.01dB above 0.5% of range.

DC AMPS

RANGE	RESOLUTION	MAXIMUM VOLTAGE BURDEN	ACCURACY (1 Yr.)
			18°-28°C ± (%rdg + counts)
200 μA	1nA	0.3V	0.1 + 15**
2mA	10nA	0.3V	0.1 + 15
20mA	100nA	0.3V	0.1 + 15
200mA	1 μA	0.3V	0.2 + 15
2000mA	10 μA	0.8V	0.2 + 15
10 A	100 μA	0.3V	0.75 + 15*

*Above 5A derate 0.15% rdg per amp for self-heating.

**When properly zeroed.

OVERLOAD PROTECTION: mA Input: 2A fuse (250V), externally accessible. 10A Input: 20A for 15s, unfused.

SETTLING TIME: 1 second to within 3 counts of final reading.

TRMS AC AMPS

RANGE	MAXIMUM VOLTAGE BURDEN	ACCURACY (1 Yr.)*		
		18°-28°C ± (%rdg + counts)		
		20Hz - 50Hz	50Hz - 10kHz	10kHz - 30kHz
200μA - 20mA	0.3V	1.0+100	0.8+100	2+250
200mA	0.3V	1.0+100	0.8+100	—
2000mA	0.8V	1.0+100	0.8+100	—
10 A	0.3V	1.5+100**	1.0+100**	—

*Above 1800 counts. **1kHz max. Above 5A derate 0.15% rdg/amp for self-heating.

SETTLING TIME: 1 second to within 0.1% of final reading.

OHMS

RANGE	RESOLUTION	NOMINAL I-SHORT	MAX V ACROSS UNKNOWN	ACCURACY	
				± (%rdg + counts)	
				24 Hr., 22°-24°C	1 Yr., 18°-28°C
200 Ω	1mΩ	2mA	0.5V	0.01 + 2*	0.02 + 3*
2 kΩ	10mΩ	2mA	4.0 V	0.01 + 2	0.018 + 2
20 kΩ	100mΩ	400 μA	4.0V	0.014 + 2	0.026 + 2
200 kΩ	1 Ω	40 μA	4.0V	0.014 + 2	0.026 + 2
2MΩ**	10 Ω	4 μA	4.0V	0.02 + 2	0.035 + 2
20MΩ**	100 Ω	400 nA	4.0V	0.10 + 2	0.12 + 2
200MΩ**	10 kΩ	400 nA	5.0V	2.00 + 1	2.00 + 1

*When properly zeroed. **Appropriate range selected automatically in MΩ.

CONFIGURATION: Automatic 2- or 4-terminal.

MAXIMUM ALLOWABLE INPUT: 450V dc or peak ac 10 seconds per minute. 350V rms continuous.

OPEN-CIRCUIT VOLTAGE: +5V.

DIODE TEST: Display reads junction voltage up to 2.2V. Test Current: 1.6mA nominal.

SETTLING TIME: 2 seconds to within 3 counts of final reading on range.

GENERAL

DISPLAY: ±220,000 count LCD, 0.45 in. height; polarity, function, range, and status indication.

RANGING: Auto or manual on dc volts, ac volts, and ohms; manual on ac amps and dc amps.

RELATIVE: Pushbutton allows zeroing of on range readings. Allows readings to be made with respect to baseline value. Front panel annunciator indicates REL mode.

DATA LOGGER and MIN/MAX: 100 reading storage capacity; records data at one of six selectable rates from 3 readings/second to 1 reading/hour or by manual triggering. Also detects and stores maximum and minimum readings continuously while in data logger mode.

CONVERSION RATE: 3 readings/second.

OVERRANGE INDICATION: "OL" displayed.

CREST FACTOR (ratio of peak value to rms value), AC FUNCTIONS: 3.

MAXIMUM COMMON MODE VOLTAGE: 500V peak.

COMMON MODE REJECTION RATIO (1kΩ unbalance): Greater than 120dB at dc, 50Hz, 60Hz ±0.1%. Greater than 60dB in ac volts.

TEMPERATURE COEFFICIENT (0°-18°C & 28°-50°C): ±(0.1× applicable one year accuracy specification)/°C.

ENVIRONMENT: Operating: 0°-50°C; less than 80% relative humidity up to 35°C; linearly derate 3% RH/°C, 35°-50°C. Storage: -25° to 60°C.

WARMUP: 1 hour to rated accuracy.

POWER: 105-125V or 210-250V (external switch selected), 90-110V available; 50-60Hz, 12V•A. Optional 5-hour battery pack. Model 1978.

DIMENSIONS, WEIGHT: 89mm high × 235mm wide × 275mm deep (3½ in. × 9¼ in. × 10¾ in.). Net weight 1.8kg (3 lbs., 14 oz.).

ACCESSORIES SUPPLIED: Model 1751 safety test leads, instruction manual.

ACCESSORIES AVAILABLE:

- Model 1010: Single Rack Mounting Kit
- Model 1017: Dual Rack Mounting Kit
- Model 1301: Temperature Probe
- Model 1600A: High Voltage Probe
- Model 1641: Kelvin Test Lead Set
- Model 1651: 50-Ampere Current Shunt
- Model 1681: Clip-On Test Lead Set
- Model 1682A: RF Probe
- Model 1684: Hard Shell Carrying Case
- Model 1685: Clamp-On Ac Probe
- Model 1751: Safety Test Leads
- Model 1754: Universal Test Lead Kit
- Model 1972: IEEE-488 with Analog Output
- Model 1973: IEEE-488 Interface
- Model 1978: Rechargeable Battery Pack
- Model 7008-3: IEEE-488 Digital Cable (3 ft.)
- Model 7008-6: IEEE-488 Digital Cable (6 ft.)
- Model 8573: IEEE-488 Interface for IBM PC (use with 1972/3)

TABLE OF CONTENTS

SECTION 1—GENERAL INFORMATION

1.1	Introduction	1-1
1.2	Features	1-1
1.3	Warranty Information	1-1
1.4	Manual Addenda	1-1
1.5	Safety Symbols and Terms	1-1
1.6	Specifications	1-2
1.7	Unpacking and Inspection	1-2
1.8	Using the Model 197 Manual	1-2
1.9	Initial Operation	1-2
1.10	Accessories	

SECTION 2—BENCH OPERATION

2.1	Introduction	2-1
2.2	High Energy Circuit Safety Precautions	2-1
2.3	Preparation For Use	2-1
2.3.1	Line Power	2-1
2.3.2	Battery Pack Power	2-2
2.3.3	Battery Charging	2-2
2.4	Front Panel Familiarization	2-2
2.4.1	Display	2-2
2.4.2	Front Panel Controls	2-3
2.4.3	Input Terminals	2-3
2.4.4	Current Fuse Replacement	2-3
2.5	Error Messages	2-4
2.6	Operating Conditions	2-4
2.6.1	Environmental Conditions	2-4
2.6.2	Maximum Allowable Inputs	2-4
2.6.3	Warm Up	2-4
2.7	Basic Bench Measurements	2-4
2.7.1	Power Up	2-5
2.7.2	Relative Mode	2-5
2.7.3	DC Voltage Measurement	2-6
2.7.4	TRMS AC Voltage Measurements	2-6
2.7.5	Microvolt Measurement Considerations	2-7
2.7.6	Resistance Measurements	2-8
2.7.7	Current Measurements (DC or TRMS AC)	2-9
2.7.8	AC Plus DC Measurements	2-10
2.7.9	dB Measurements	2-10
2.7.10	dB Measurements Considerations and Applications	2-12
2.7.11	MIN/MAX and 100 Point Data Logger Operation	2-13
2.7.12	Diode Test	2-13
2.8	TRMS Considerations	2-13
2.8.1	AC Voltage Offset	2-14
2.8.2	TRMS Measurement Comparison	2-14
2.8.3	Crest Factor	2-14
2.8.4	Extended Frequency Response	2-14

SECTION 3—PERFORMANCE VERIFICATION

3.1	Introduction	3-1
3.2	Environmental Conditions	3-1
3.3	Recommended Test Equipment	3-1
3.4	Initial Conditions	3-1
3.5	Verification Procedure	3-1
3.5.1	DC Voltage Accuracy Check	3-2
3.5.2	AC Voltage Accuracy Check	3-2
3.5.3	Resistance Accuracy Check	3-3
3.5.4	DC Current Accuracy Check	3-4
3.5.5	AC Current Accuracy Check	3-5

SECTION 4—THEORY OF OPERATION

4.1	Introduction	4-1
4.2	Overall Functional Description	4-1
4.3	Analog Circuitry	4-1
4.3.1	Multiplexer	4-1
4.3.2	Input Buffer Amplifier	4-1
4.3.3	2V Reference Source	4-1
4.3.4	Input Signal Conditioning	4-1
4.3.5	A/D Converter	4-4
4.3.6	AC Converter	4-5
4.4	Digital Circuitry	4-5
4.4.1	Microcomputer	4-5
4.4.2	Address Decoding	4-6
4.4.3	PIA	4-6
4.4.4	Display Board	4-6
4.5	Digital Calibration	4-6
4.6	Power Supply	4-6
4.7	Model 1978 Battery Option	4-7

SECTION 5—MAINTENANCE

5.1	Introduction	5-1
5.2	Top Cover Removal/Installation	5-1
5.3	Battery Pack (Model 1978) Installation	5-1
5.4	Line Voltage Selection	5-2
5.5	Fuse Replacement	5-2
5.5.1	Line Fuse Replacement	5-2
5.5.2	Current Fuse Replacement	5-2
5.6	Front Panel Calibration	5-4
5.6.1	Recommended Calibration Equipment	5-4
5.6.2	Environmental Conditions	5-4
5.6.3	Calibration Jumper	5-4
5.6.4	DC Voltage Calibration	5-5
5.6.5	AC Voltage Calibration	5-5
5.6.6	Frequency Compensation	5-5
5.6.7	Resistance Calibration	5-7
5.6.8	Calibration Storage	5-7
5.7	Troubleshooting	5-8
5.7.1	Power Up Sequence	5-8
5.7.2	Self Diagnostic Program	5-8
5.7.3	Power Supply and Battery Pack (Model 1978) Checks	5-9

5.7.4	A/D Converter and Display	5-9
5.7.5	Signal Conditioning	5-9
5.8	Special Handling of Static Sensitive Devices	5-9

SECTION 6—REPLACEABLE PARTS

6.1	Introduction	6-1
6.2	Replaceable Parts	6-1
6.3	Ordering Information	6-1
6.4	Factory Service	6-1
6.5	Schematic Diagrams and Component Location Drawings	6-1

LIST OF TABLES

2-1	Error Messages	2-4
2-2	Model 197 Maximum Allowable Inputs	2-5
2-3	Resistance Range Output Values	2-8
2-4	dB Specification for DC Volts (600Ω Ref)	2-10
2-5	dB Specification for AC Volts (600Ω Ref)	2-11
2-6	Levels for Other Reference Impedances	2-12
2-7	Comparison of Average and TRMS Meter Readings	2-15
3-1	Recommended Test Equipment	3-1
3-2	Limits for DC Voltage Verification	3-2
3-3	Limits for AC Voltage Verification	3-3
3-4	Limits for Resistance Verification	3-3
3-5	Limits for DC Current Verification	3-4
3-6	Limits for AC Current Verification	3-6
5-1	Recommended Calibration Equipment	5-4
5-2	DC Voltage Calibration	5-5
5-3	AC Voltage Calibration	5-6
5-4	Resistance Calibration	5-7
5-5	Recommended Troubleshooting Equipment	5-8
5-6	Model 197 Troubleshooting Mode	5-10
5-7	Power Supply and Battery Pack (Model 1978) Checks	5-12
5-8	Display Board Checks	5-12
5-9	A/D Converter Checks	5-13
5-10	Model 197 Static Sensitive Devices	5-13
6-1	Model 197 Parts List	6-3
6-2	Display Board, Parts List	6-6
6-3	Model 1978 Battery Pack, Parts List	6-6

LIST OF ILLUSTRATIONS

2-1	Model 197 Front Panel	2-2
2-2	DC Voltage Measurements	2-6
2-3	TRMS AC Voltage Measurements	2-7
2-4	Two Terminal Resistance Measurement	2-9
2-5	Four Terminal Resistance Measurement	2-9
2-6	Four Terminal Zeroing	2-9
2-7	Current Measurements Between 2000mA and 20A	2-10
2-8	Current Measurements up to 2000mA	2-10
2-9	Typical ACV Frequency Response	2-15
3-1	Connections for DCV Verification	3-2
3-2	Connections for ACV Verification	3-3
3-3	Connections for 200, 2k and 20k Range Verification (4-Terminal)	3-4
3-4	Connections for 200k through M Ω Ranges Verification (2-Terminal)	3-4
3-5	Connections for DC Current Verification (200 μ A to 2000mA)	3-5
3-6	Connections for DC Current Verification (2000mA to 20A)	3-5
3-7	Connections for AC Current Verification (200 μ A to 2000mA)	3-6
3-8	Connections for AC Current Verification (2000mA to 10A)	3-6
4-1	Simplified Block Diagram	4-2
4-2	JFET Multiplexer	4-3
4-3	Simplified Schematic of the Input Buffer Amplifier	4-3
4-4	Input Configuration During 2- and 4-Terminal Resistance Measurements	4-4
4-5	Resistance Measurement Simplified Circuit	4-5
4-6	A/D Converter	4-6
5-1	Model 197 Miscellaneous Parts	5-3
5-2	DELETED ON REVISION C	5-5
5-3	DC Voltage Calibration Configuration	5-5
5-4	AC Voltage Calibration Configuration	5-7
5-5	200, 2k and 20k Four Wire Resistance Calibration	5-7
5-6	200k, 2M and 20M Two Wire Resistance Calibration	5-7
5-7	Segment Identification	5-9
6-1	Display Assembly, Exploded View	6-1
6-2	Model 1978 Battery Pack, Component Location Drawing, Dwg. No. 1978-100	6-7
6-3	Mother Board, Component Location Drawing, Dwg. No. 197-100	6-9
6-4	Display Board, Component Location Drawing, Dwg. No. 197-110	6-11
6-5	Mother Board, Schematic Diagram, Dwg. No. 197-106	6-13
6-6	Display Board, Schematic Diagram, Dwg. No. 197-116	6-15
6-7	Model 1978 Battery Pack, Schematic Diagram, Dwg. No. 1978-106	6-17

SAFETY PRECAUTIONS

The following safety precautions should be observed before operating the Model 197.

This instrument is intended for use by qualified personnel who recognize shock hazards and are familiar with the safety precautions required to avoid possible injury. Read over the manual carefully before operating this instrument.

Exercise extreme caution when a shock hazard is present at the instrument's input. The American National Standards Institute (ANSI) states that a shock hazard exists when voltage levels greater than 30V rms or 42.4V peak are present. **A good safety practice is to expect that a hazardous voltage is present in any unknown circuit before measuring.**

Inspect the test leads for possible wear, cracks or breaks before each use. If any defects are found, replace with test leads that have the same measure of safety as those supplied with the instrument.

For optimum safety do not touch the test leads or the instrument while power is applied to the circuit under test. Turn the power off and discharge all capacitors, before connecting or disconnecting the instrument. Always disconnect all unused test leads from the instrument.

Do not touch any object which could provide a current path to the common side of the circuit under test or power line (earth) ground. Always make measurements with dry hands while standing on a dry, insulated surface, capable of withstanding the voltage being measured.

Exercise extreme safety when testing high energy power circuits (AC line or mains, etc). Refer to the operation section.

Do not exceed the instrument's maximum allowable input as defined in the specifications and operation section.

SECTION 1

GENERAL INFORMATION

1.1 INTRODUCTION

The Model 197 is a six function, 5½ digit resolution autoranging digital multimeter with a ±220,000 count LCD (Liquid Crystal Display). This A/D range is greater than the normal ±199,999 count A/D used in many 5½ digit DMMs. The 5½ digit resolution allows the Model 197 to measure DC voltage from 1μV/count to 1000V. AC voltage and current measurements are standard in the Model 197. TRMS ACV capability ranges from 1μV/count to 750V. The Model 197 measures resistance from 1mΩ to 220MΩ on seven resistance ranges. The Model 197 has six current ranges that measure current from 1nA (10⁻⁹A) to 10A.

The dB function makes it possible to compress a large range of readings into a much smaller scope. The Model 197 dBm measurements are referenced to the standard 600Ω impedance but can be modified with the use of relative (REL) feature.

The Model 197 has two IEEE-488 interface options: The Model 1972 and the Model 1973. These optional interfaces enhance the capabilities of the Model 197 by allowing programmed control over the IEEE-488 bus. The Model 1972 also includes an analog output. The bus commands are the same for each interface and respond to IEEE-488 protocol.

1.2 FEATURES

The Model 197 includes the following features:

1. Six Measurement Functions—DCV, ACV, DCA, ACA, OHMS and dB all built in.
2. (REL) Relative Mode—The relative mode allows offsets to be nulled out (e.g. test lead resistance for low resistance measurements) and selects a variety of reference impedances for dB measurements.
3. Digital Calibration—A non-volatile RAM stores calibration constants and can be performed from the front panel or over the IEEE-488 bus.
4. Data Logger—A data storage buffer is included to allow up to 100 readings and minimum/maximum readings be internally stored at a user selectable rate. The buffer may be read and controlled from the front panel or over the IEEE-488 bus. In the talk-only mode, the output rate can also be programmed.
5. Autoranging—The Model 197 includes a fast autoranging feature for easier measurements.
6. 5½ Digit Resolution—The Model 197 has a ±220,000 count A/D that surpasses the more common ±199,999 count A/D.
7. Four Terminal Ohms—These terminals are used to eliminate the voltage drop across the current carrying leads.
8. Sensitivity—The Model 197 has 1μV, 1mΩ and 1nA sensitivity. The 1μV of sensitivity allows minute levels of offset, temperature etc. A 1nA sensitivity allows low current measurements without special equipment. Measure leakage, bias and offset current. A 1mΩ sensitivity allows easy low resistance measurements.

1.3 WARRANTY INFORMATION

Warranty information may be found on the inside front cover of this manual. Should it become necessary to exercise the warranty, contact your Keithley representative or the factory to determine the proper course of action. Keithley Instruments maintains service facilities in the United States, United Kingdom and throughout Europe. Information concerning the application, operation or service of your instrument may be directed to the applications engineer at any of these locations. Check the inside front cover for addresses.

1.4 MANUAL ADDENDA

Information concerning improvements or changes to this instrument which occur after the printing of this manual will be found on an addendum sheet included with this manual. Be sure to review these changes before attempting to operate or service the instrument.

1.5 SAFETY SYMBOLS AND TERMS

The following safety symbols and terms are used in this manual or found on the Model 197.

The symbol  on the instrument denotes the user should refer to the operating instructions in this manual.

The symbol  on the instrument denotes that a potential of 1000V or more may be present on the terminal(s). Standard safety practices should be observed when such dangerous levels are encountered.

The **WARNING** heading used in this manual explain dangers that could result in personal injury or death.

The **CAUTION** heading used in this manual explain hazards that could damage the instrument.

1.6 SPECIFICATIONS

Detailed Model 197 specifications may be found preceding the table of contents of this manual.

1.7 UNPACKING AND INSPECTION

The Model 197 Autoranging Microvolt DMM was carefully inspected, both electrically and mechanically before shipment. Upon receiving the instrument, carefully unpack all items from the shipping carton and check for any obvious signs of physical damage that may have occurred during transit. Report any damage to the shipping agent. Retain and use the original packing materials in case reshipment is necessary. The following items are shipped with every Model 197 order:

- Model 197 Autoranging DMM
- Model 197 Instruction Manual
- Model 1751 Safety Shrouded Test Leads
- Additional accessories as ordered.

If an additional instruction manual is required, order the manual package (Keithley Part Number 197-901-00). The manual package includes an instruction manual and any applicable addenda.

1.8 USING THE MODEL 197 MANUAL

This manual contains information necessary for operating and servicing the Model 197 Autoranging Microvolt DMM and the Model 1978 Rechargeable Battery Pack. The information is divided into the following sections.

1. Section 2 contains detailed bench operation information for the Model 197.
2. Section 3 contains the information needed to verify the accuracy of the Model 197. Performance verification can be done upon receipt of the unit or whenever the basic accuracy of the instrument is in question.
3. Information concerning theory of operation, maintenance and servicing is contained in Sections 4 through 6.

NOTE

The Models 1973 and 1972 IEEE-488 interfaces come supplied with their own instruction manual.

1.9 INITIAL OPERATION

Perform the following steps in sequence to acquaint yourself with the basic operation of the Model 197.

- Verify that the instrument was not damaged in transit, (see paragraph 1.7).
- Carefully read over all safety information (see Section 2 Basic Operation).
- Refer to paragraph 2.3 (Line Power) and set the line voltage switch. Plug the power cord into a properly grounded receptacle. If the Model 1978 is installed the charging circuit is activated.
- Acquaint yourself with the front panel controls as follows:
 1. Turn on the instrument using the ON/OFF button. All of the zeroes are briefly displayed.
 2. Connect the supplied test leads to the HI and LO input terminals. Connect the red test lead to the HI terminal and the black test lead to the LO terminal. Short the test leads together.
 3. Select AC volts and autoranging by pressing in the AC/DC, V and AUTO buttons. The AC, AUTO and mV annunciators are displayed. Pressing in any of the other range buttons activates manual ranging. This is indicated by the absence of the AUTO annunciator.
 4. Select DC volts by releasing (out position) the AC/DC button. V is still selected. The AC annunciator turns off.
 5. Select the autoranging OHMS by pressing in the AUTO, and Ω buttons. DC must still be selected. The Ω (omega) symbol is displayed. Press the AC/DC button in (means select AC) and note that the "Err" message is displayed. This indicates an invalid mode.
 6. Select AC or DC current by setting the AC/DC button accordingly and pressing in the A button. The annunciator that reflects the selected mode is displayed. Note that current will not autorange. The 10A and LO terminals must be used on the 10A range.
 7. Select dB by selecting AC or DC volts and pressing the dB button. The dB annunciator is now displayed. Press the dB button to take the instrument out of the dB mode.
 8. The REL (relative) feature can be used with any measurement function: Volts, Amps, Ohms or dB. For example, select the ohms function and autorange. The display reads approximately 000.140 Ω , which is the test lead resistance. Press the REL button. The REL annunciator is turned on and the display reads 000.000 Ω . The relative level of 000.14 Ω will be subtracted from all subsequent measurements. Press the REL button a second time to cancel the REL level.

9. To activate the 100 point DATA LOGGER with minimum/maximum, press and hold in the STO/CLR button. When the reading rate $r=0$ is displayed release the STO/CLR button. The STO annunciator turns on. Press the RCL button and the last data point is briefly displayed followed by the reading (data). Other data points can be displayed by holding in the RCL button. Turn off the DATA LOGGER by pressing the STO/CLR button again.

1.10 ACCESSORIES

The following accessories can be used with the Model 197.

MODEL 1010 SINGLE RACK MOUNTING KIT—Used to mount one Model 197 in a standard $5\frac{1}{4}'' \times 19''$ rack.

MODEL 1017 DUAL RACK MOUNTING KIT—Use to mount two Model 197s in a standard $5\frac{1}{4}'' \times 19''$ rack.

MODEL 1301 TEMPERATURE PROBE—A rugged low cost temperature probe designed to allow precision temperature measurements from -55 to 150°C .

MODEL 1600A HIGH VOLTAGE PROBE—Extends DMM measurements to 40kV .

Model 1641 Kelvin Test Lead Set—Special clip leads allow 4-terminal measurements to be made while making only two connections.

MODEL 1651 50-AMPERE CURRENT SHUNT—The external $0.001\Omega \pm 1\%$ 4-terminal shunt, permits current measurements from 0 to 50A AC or DC.

MODEL 1681 CLIP ON TEST LEAD SET—Contains two leads, 1.2m ($48''$) long terminated with banana plugs and spring action clip probes.

MODEL 1682A RF PROBE—Permits voltage measurements from 100kHz to 250MHz . AC to DC transfer accuracy is $\pm 1\text{dB}$ from 100kHz to 250MHz at 1V , peak responding, calibrated in RMS of a sine wave.

MODEL 1684 HARD SHELL CARRYING CASE—Hard vinyl case, $100\text{mm} \times 300\text{mm} \times 350\text{mm}$ ($4'' \times 13'' \times 14''$) has a fitted foam insert with room for the Model 197, an instruction manual and small accessories.

MODEL 1685 CLAMP ON AC PROBE—Measures AC current by clamping on to a single conductor. Interruption of the circuit is unnecessary. The Model 1685 detects currents by sensing the changing magnetic field produced by the current flow.

MODEL 1751 SAFETY TEST LEADS—This test lead set is supplied with every Model 197. Finger guards and shrouded banana plugs help minimize the chance of making contact with live circuitry.

MODEL 1754 UNIVERSAL TEST LEAD KIT—A 12 piece test lead kit, with interchangeable plug-in accessories. Included in the kit is one set of test leads (1-red, 1-black), two spade lugs, two standard banana plugs, two phone tips ($.06$ DIA.) two hooks and miniature alligator clips (with boots).

MODEL 1972 ANALOG OUTPUT IEEE-488 INTERFACE—The Model 1972 is an optional IEEE-488 interface that includes all of the logic necessary to interface the Model 197 to the IEEE-488 bus. The Model 1972 is similar to the Model 1973 however, it contains an analog output. The analog output is a scaled output that follows the display of the Model 197. The Model 1972 is field installable.

MODEL 1973 IEEE-488 INTERFACE—The Model 1973 is an optional IEEE-488 interface for the Model 197. This interface adds extra versatility to the Model 197 by allowing the transmission of data and commands over the IEEE-488 bus. The interface provides all the logic necessary to interface the Model 197 to the bus using standard IEEE-488-1978 protocol. The Model 1973 is field installable.

MODEL 1978 RECHARGEABLE BATTERY PACK—The rechargeable battery pack allows off line or in the field operation of the Model 197. The pack provides typically five hours operation from full charge. The battery pack contains its own charging circuit and can be recharged within 10 hours. The battery pack is field installable.

MODEL 7008 IEEE-488 DIGITAL CABLE—Useful for connecting the 1973 to the IEEE-488 bus. The Model 7008-3 is 0.9m (3ft.) in length and has a standard IEEE-488 connector at each end. The Model 7008-6 is 1.8m (6ft.) in length and has a standard IEEE-488 connector at each end.

MODEL 8573 IEEE-488 INTERFACE—The Model 8573 is an IEEE-488 standard interface designed to interface the IBM PC or XT computers to Keithley instrumentation over the IEEE-488 bus. The interface system contains two distinct parts: an interface board containing logic to perform the necessary hardware functions and the handler software (supplied on disk) to perform the required control functions. These two important facets of the Model 8573 join together to give the IBM advanced capabilities over IEEE-488 interfaceable instrumentation.

SECTION 2

BENCH OPERATION

2.1 INTRODUCTION

This section contains the information needed to prepare and operate the Model 197 as a bench DMM. Bench operation consists of using the Model 197 to perform basic voltage, current, resistance and dB measurements. Also, the operation of the data logger is covered. The capabilities of the Model 197 can be enhanced with the addition of the Model 1973 or Model 1972 IEEE-488 interface. IEEE operation is covered in the Model 1973 Instruction Manual. The optional battery pack (Model 1978) is also covered in this section.

2.2 HIGH ENERGY CIRCUIT SAFETY PRECAUTIONS

To optimize safety when measuring voltage in high energy distribution circuits, read and use the directions in the following warning.

WARNING

Dangerous arcs of an explosive nature in a high energy circuit can cause severe personal injury or death. If the meter is connected to a high energy circuit when set to a current range, low resistance range or any other low impedance range, the circuit is virtually shorted. Dangerous arcing can result even when the meter is set to voltage range if the minimum voltage spacing is reduced.

When making measurements in high energy circuits use test leads that meet the following requirements:

- Test leads should be fully insulated.
- Only use test leads that can be connected to the circuit (e.g. alligator clips, spade lugs, etc.) for hands-off measurements.
- Do not use test leads that decrease voltage spacing. This diminishes arc protection and creates a hazardous condition.

Use the following sequence when testing power circuits:

1. De-energize the circuit using the regular installed connect-disconnect device such as the circuit breaker, main switch, etc.

2. Attach the test leads to the circuit under test. Use appropriate safety rated test leads for this application.
3. Set the DMM to the proper function and range.
4. Energize the circuit using the installed connect-disconnect device and make measurements without disconnecting the DMM.
5. De-energize the circuit using the installed connect-disconnect device.
6. Disconnect the test leads from the circuit under test.

2.3 PREPARATION FOR USE

2.3.1 Line Power

The Model 197 has a three-wire line cord which mates with third-wire grounded receptacles. Connect the instrument to AC line power as follows:

1. Set the LINE VOLTAGE switch on the back of the instrument to correspond to line voltage available. Ranges are 105V-125V or 210V-250V 50/60Hz AC.

CAUTION

Connect only to the line voltage selected. Application of incorrect voltage can damage the instrument.

2. Plug the power cord into a properly grounded outlet.

WARNING

Ground the instrument through a properly grounded receptacle before operation. Failure to ground the instrument can result in severe injury or death in event of a short circuit or malfunction.

NOTE

Although the Model 197 is specified at 50 and 60Hz the instrument may be operated at 400Hz and 440Hz.

2.3.2 Battery Pack Power

The Model 197 may be operated from rechargeable sealed nickel-cadmium batteries contained in the optional Model 1978 Rechargeable Battery Pack. The battery pack will operate the Model 197 for typically five hours. (NOTE: The Model 197 uses the most power on the amps function and also in the 200Ω, 2kΩ or 750VAC ranges). The BAT annunciator turns on when the charge is insufficient to maintain accurate readings. Refer to paragraph 5.3 for installation procedures.

2.3.3 Battery Charging

After the Model 1978 is installed in the Model 197 it can be charged and recharged as follows:

1. Connect the instrument to line power as described in paragraph 2.3.1.
2. With the power switch off, the battery charge circuitry is automatically energized to charge the battery at the maximum rate. When the battery pack is first installed, or if it is completely discharged, allow it to charge for a minimum of 10 hours.

NOTE

For maximum battery efficiency only charge the battery pack after it has become completely discharged (BAT annunciator on). Do not make measurements with BAT annunciator on as the readings may be erroneous.

If the battery pack is not maintaining a charge (BAT off) for five hours after a full 10 hour charge cycle, do the following.

- A. Disconnect the Model 197 from line power.
 - B. Turn on the Model 197 and leave it on to completely discharge the battery pack.
 - C. Connect the Model 197 to line power and charge the battery pack for 10 hours with power off.
 - D. Repeat steps A through C three more times. The battery pack should again be good for typically five hours.
3. When the Model 197 is in use on line power, the battery charger maintains a trickle charge on the battery pack.

NOTE

The IEEE options (Model 1972 and Model 1973) do not run off of battery power.

2.4 FRONT PANEL FAMILIARIZATION

Figure 2-1, and the following paragraphs, provide a brief description of the display, front panel controls and input terminals.

2.4.1 Display

The Model 197 has a 5½ digit liquid crystal display (LCD). The minus sign is displayed. The plus sign is implied by the absence of the minus sign. The following annunciators are displayed on the LCD.

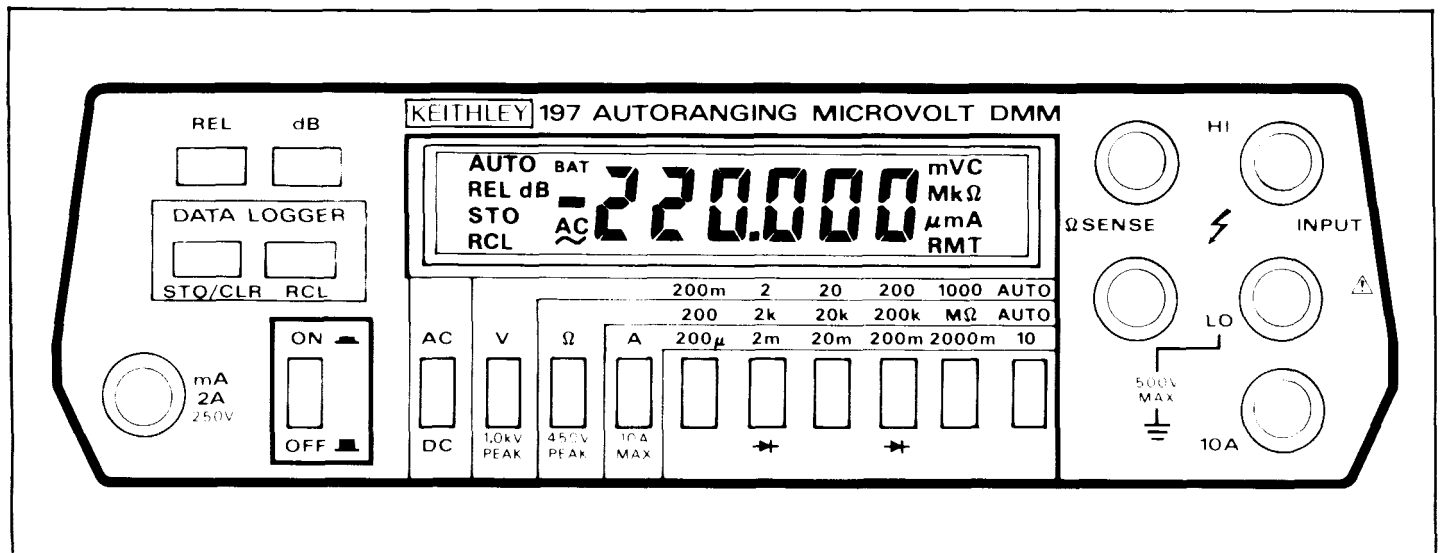

Figure 2-1. Model 197 Front Panel

BAT—Low battery indicator for the Model 1978.

AC—AC selected (DC implied by the absence of the AC annunciator).

mV or V—Millivolts or volts.

Ω , k Ω or M Ω —Ohms, kilohms or megohms.

μ , mA or A—Microamps, milliamps or amps.

RMT (REMOTE)—Model 197 being controlled over the IEEE-488 bus (Model 1973 or Model 1972 installed).

C—Model 197 in calibration mode.

AUTO—Autorange.

REL—Relative.

dB—Decibel measurement mode.

STO—Data being stored.

RCL—Data being recalled. RCL flashes when buffer is full during logging cycle.

2.4.2 Front Panel Controls

ON/OFF—Pressing this button turns on the Model 197. Releasing (out) this button turns the instrument off.

REL-(RELATIVE)—This button allows readings to be made with respect to any baseline value. Also allows zeroing of on range readings. See paragraph 2.7.2 for more detailed information on REL.

dB—This button selects the dB function and is used along with the ACV or DCV function. Measurements are made in dBm referenced to 600 Ω . REL can be used to make any voltage level the 0dB reference point for dB measurements.

DATA LOGGER and MIN/MAX—100 reading storage capacity; records data at one of seven selectable rates from 3 reading/second to 1 reading/hour or by manual trigger ($r=6$). Also detects and stores maximum and minimum readings continuously while in the data logger mode.

1. STO/CLR—Pressing this button initiates the logging sequence. Pressing this button a second time turns off the data logger. For $r=6$ rate (manual trigger) every time a reading is desired, press the STO/CLR button.
2. RCL—Pressing and holding in this button scrolls the data pointer. To read the data at a certain point, simply release the button. The logged readings are stored in buffer locations 01 to 102. They are depicted on the front panel as follows: Buffer location #1 is represented by $n=01$.

AC/DC—This button is used along with the volts (V), current (A), and dB functions. Depressing (in) this button selects AC, releasing (out) this button selects DC. AC Ω is invalid condition. See Table 2-1.

V—Depressing this button selects the volts function.

Ω —Depressing this button selects the ohms function. The AC/DC button must be released (out).

A—Depressing (in) this button selects the current function. Up to 2A on red and black input jacks and up to 10A with the black and white input jacks. Refer to paragraph 2.4.3.

RANGE BUTTONS

1. Depressing AUTO button allows volts and ohms to autorange. In current, it selects the 10A range. There is no autorange function for current.
2. Manual ranging is accomplished by depressing the appropriate range button.

2.4.3 Input Terminals

The input terminals are intended to be used with safety shrouded test leads to help minimize the possibility of contact with live circuits. Safety shrouded test leads (Model 1751) are supplied with the Model 197. Always disconnect all unused test leads from the instrument.

HI and LO INPUT (Red and Black)—Use this pair of terminals for all volt, ohm, milliamp and dB measurements.

10A and LO (White and Black)—Use this pair of terminals for measuring current up to 10A (up to 20A for 15 seconds).

OHMS Sense HI and LO—Use this pair of terminals along with HI and LO input for four wire resistance measurements.

2.4.4 Current Fuse Replacement

The current fuse protects the 200 μ A through 2000mA ranges from an input current greater than 2A. To replace the current fuse, perform the following steps:

NOTE

The front panel current fuse (F101) is rated at 2A. With a 220,000 count display, the 2A range

can momentarily (approx. one minute) read 2.2A before the fuse will blow. This 10% over-range will not harm the instrument.

1. Turn off the power and disconnect the power line and test leads.
2. Place the end of a flat-blade screwdriver into the slot in the fuse holder on the front panel. Press in slightly and rotate the fuse carrier one quarter turn counterclockwise. Release pressure and remove the fuse carrier and the fuse.
3. Remove the defective fuse and replace it with the following type: 2A, 250V, 3AG, normal-blow (Keithley part number FU-13) or equivalent.

CAUTION

Use only the recommended fuse type. If a fuse with a higher current rating is installed, instrument damage may occur.

2.5 ERROR MESSAGES

Table 2-1 lists the error messages associated with basic front panel operation. Note that the instrument has a number of other messages that are discussed in the appropriate sections of the manual.

2.6 OPERATING CONDITIONS

2.6.1 Environmental Conditions

All measurements should be made at an ambient temperature within the range of 0°C to 50°C, and with a relative humidity

of less than 80% up to 35°C. For ambient above 35°C derate humidity 3% per °C up to 50°C. If the instrument has been subjected to extremes of temperature, allow sufficient time for internal temperature to reach environmental conditions. Typically, it takes one hour to stabilize a unit that is 10°C (18°F) out of the specified temperature range.

2.6.2 Maximum Allowable Inputs

Table 2-2 lists the maximum allowable inputs for the Model 197.

2.6.3 Warm Up

The Model 197 requires one hour for warm up to achieve rated accuracy.

2.7 BASIC BENCH MEASUREMENTS

Basic measurement techniques for using the Model 197 to measure AC and DC volts, resistance, AC and DC current and dB are covered in the following paragraphs. Also included is the operation of the minimum/maximum and 100 point data logger.

WARNING

Before operating the Model 197, observe all previously mentioned safety precautions. When testing high energy power circuits follow the instructions found in paragraph 2.2. Failure to observe these and other safe-

Table 2-1. Error Messages

Display	Message	Comments
	RAM Error	Model 197 locks up. See Section 5 for troubleshooting information.
	Calibration Error (NVRAM Failure)	Model 197 locks up, but operation can be restored by pressing any one of the four momentary pushbuttons. If restored, calibration is invalid as indicated by the flashing "C" annunciator. See Section 5 for troubleshooting information.
	Overrange	Overrange input applied to the Model 197. Leading minus sign indicates that input signal has a negative value.
	Invalid Ω Function	"AC" and "Ω" annunciators flash. Correct problem by releasing (out) AC/DC pushbutton.

Table 2-2. Model 197 Maximum Allowable Inputs

Function	Ranges	Maximum Allowable Inputs
DCV	200mV, 2V	1000VDC or peak AC for less than 10sec per minute. 300Vrms continuous.
	20-1000V	1000VDC or peak AC.
ACV	200mV, 2V	750Vrms, 1000V peak for less than 10sec per minute. 300Vrms, continuous. 10 ⁷ •Hz maximum.
	20-750V	750Vrms, 1000V peak. 10 ⁷ •Hz maximum.
DCA, ACA	200 μ -2000mA	2A, 250VDC or rms (fuse protected).
	10A	10A continuous; 20A for 15sec (unfused).
Ω	All	450V peak AC or DC, 10 seconds per minute, 350Vrms continuous.

ty precautions mentioned in this manual could result in severe injury or death.

The LO terminal on the Model 197 is designed to float above earth ground to avoid ground loop problems.

WARNING

Hazardous voltage may be applied to the LO terminal. The maximum allowable voltage between the LO terminal and chassis ground is 500V. Destruction of insulation, which could present a shock hazard, may occur if the 500V maximum is exceeded.

CAUTION

Do not exceed the maximum input limits shown in Table 2-2.

2.7.1 Power Up

NOTE

The software revision level of the Model 197 can be displayed upon power up by running the diagnostic program. See Section 5, Maintenance, for more information.

Turn on the Model 197 by pressing in the ON/OFF switch. All zeroes are briefly displayed before going into the measurement mode.

NOTE

If the Model 197 does not enter the measurement mode, refer to section 5.7.1.

2.7.2 Relative Mode

When the relative mode is selected with an on-scale reading on the display the following occurs:

1. The REL annunciator is displayed.
2. The next reading is stored.
3. This reading is algebraically subtracted from all subsequent readings and displayed.

A REL level can be established for any measurement function (Volts, Ohms, Amps and dB) and is effective only on that function. Changing functions will not affect a REL level already established. However, if another REL level is set (on any function) the previous REL level is cancelled. For example, place the Model 197 in the ohms function and select the 200 Ω range. Short the test leads and press the REL button. Note that the REL annunciator is on. Select DCV and note that the REL annunciator is off, indicating that there is not a REL level established for DCV. Switch back to ohms and note that the REL level is still there. Again, go to DCV and set a REL level of +1V. The REL annunciator turns on. Switch back to ohms and note that the REL level for ohms is cancelled.

It is important to remember what the REL function does. The REL function establishes a baseline. That baseline is algebraically subtracted from all subsequent readings for that function.

Once a REL level is established for a measurement function, that stored level will be the same regardless of what range the Model 197 is on. For example, if +1V is established as the REL level on the 20VDC range, +1V is also the REL level for other DCV ranges.

The dynamic range of the display is $\pm 400,000$ counts. This means that if a REL level of $-2.00000V$ is established, then applying $+1.99999V$ to the input displays $+3.99999V$. Once the REL level is established, that level is algebraically subtracted from the input signal. For example: if a $+1.00000V$ REL level is established, then applying a $+2.00000V$ level displays a $+1.00000V$ level.

The instrument accepts a $\pm 220,000$ count input before going into the overrange condition (OL). For example: $-1.00000V$ REL level is established and $1.50000V$ is applied. The instrument displays $+2.500000V$. If the input is $2.20000V$ the instrument overranges.

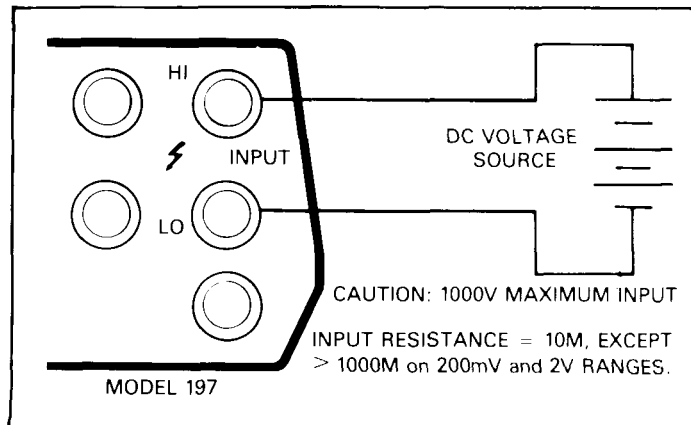

Figure 2-2. DC Voltage Measurements

2.7.3 DC Voltage Measurement

The Model 197 can make DC voltage measurements between $1\mu V$ and $1000V$. The basic procedure is as follows:

1. Connect the test leads to the HI and LO INPUT terminals of the Model 197.
2. Select the DCV function.
3. Select a range consistent with the expected voltage. For automatic range selection, press in the AUTO button.

NOTE

To prolong instrument life, manual ranging is recommended for routine measurements above $200V$.

4. Connect the test leads to the source as shown in Figure 2-2. If the positive source terminal is connected to the LO terminal of the instrument, the display shows a negative value. If the negative source terminal is connected to the LO terminal, the display shows a positive value.
5. Observe the display; If the "OL" message is shown, select a higher range until a normal reading is displayed. Always use the lowest possible range for the best resolution.
6. Take the reading from the display.

The term "when properly zeroed" means that the user must establish a proper baseline for subsequent measurements on that range. To zero the Model 197 use the following procedure:

1. Short the INPUT HI and LO test leads together.
2. Wait until the displayed reading settles. Noise and thermal emfs may require a few moments to settle out.
3. Press the REL button.

The $200mV$ DC range and the 200Ω range require zero to be set in order to achieve rated accuracy.

2.7.4 TRMS AC Voltage Measurements

The Model 197 can make TRMS AC voltage measurements between $1\mu V$ and $750V$. To measure AC proceed as follows:

1. Connect the test leads to the HI and LO terminals of the Model 197.
2. Select the ACV function.
3. Select a range consistent with the expected voltage. For automatic range selection, press in the AUTO button.
4. Connect the test leads to the source as shown in Figure 2-3.

NOTE

There is a small amount of offset (typically 50 counts or less) present when using the AC function. Do not REL this level out. The reason for this is that the offset is generally negligible as compared to the input signal. For example:

$$\begin{aligned} \text{offset} &= 22\mu V \\ \text{applied signal} &= 20mV \\ \text{displayed reading} &= \sqrt{(20mV)^2 + (22\mu V)^2} \\ &= \sqrt{.0004 + 484 \times 10^{-12}} \\ &= .0200000121 \end{aligned}$$

This offset is seen as the last digit which is not displayed on the Model 197. Therefore, the offset is negligible.

5. Observe the display, if the "OL" message is shown, select a higher range until a normal reading is displayed. Always use the lowest possible range to obtain the best resolution.

6. Take the reading from the display.

NOTE

See paragraph 2.8 for TRMS considerations. When measuring AC signals disconnect any test leads from the OHMS SENSE terminals.

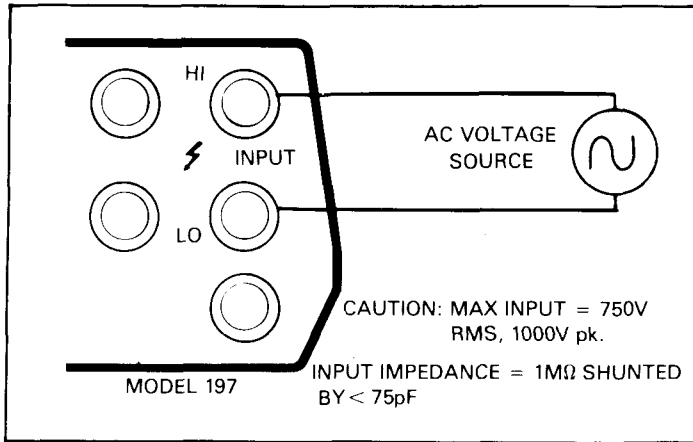

Figure 2-3. TRMS AC Voltage Measurements

2.7.5 Microvolt Measurement Considerations

Accuracy Considerations—For sensitive measurements, other external considerations besides the Model 197 will affect the accuracy. Effects not noticeable when working with higher voltages are significant in microvolt signals. The Model 197 reads only the signal received at its input; therefore, it is important that this signal be properly transmitted from the source. The following paragraphs indicate factors which affect accuracy, noise, source resistance, thermal emfs and stray pick-up.

Noise and Source Resistance—The limit of resolution in measuring voltages with the Model 197 is determined by the noise present. The displayed noise of the Model 197 is 1.5μV peak to peak. This noise is inherent in the Model 197 and is the minimum amount present in all measurements. The 1.5μV of noise is due to the instrument voltage noise. The noise at the Model 197 input increases beyond this minimum when the noise current passes through a resistor thus generating a voltage noise. The total noise becomes a function of the source resistance and is given by the equation:

$$n^2 = e_n^2 + (i_n R_s)^2 + e_r^2$$

where

n = total noise input.

e_n = input voltage noise of the Model 197.

i_n = input current noise.

R_s = parallel combination of source resistance and input impedance.

e_r = Johnson noise of the source resistance.

Even on most sensitive range, the noise due to the current is not appreciable until R_s reaches approximately 1MΩ. Thus, for an R_s of 0Ω to 1MΩ, the noise at the input is the inherent 1.5μV peak to peak. Beyond 1MΩ the noise due to R_s becomes a limiting factor in the measurement. Therefore, it is recommended that for sensitive measurements R_s be kept relatively low, if possible below 1MΩ.

As an example of determining e_r noise voltage generation (due to Johnson noise of the source resistance) assume that the Model 197 is connected to a voltage source with an internal resistance of 1MΩ. At a room temperature of 20°C (293K), the p-p noise voltage generated over a bandwidth of 1Hz will be:

$$e_r = 6.35 \times 10^{-10} \sqrt{R \times f}$$

$$e_r = 6.35 \times 10^{-10} \sqrt{(1 \times 10^6)(1)}$$

$$e_r = 0.635 \mu V$$

Thus it is clear that optimum microvolt measurements with the Model 197 are possible with source resistances as high as 1MΩ. However, this resolution will not be realized unless shielding is employed.

Shielding—The Model 197 is insensitive to AC voltages superimposed upon a DC signal at the input terminals. However, AC voltages which are extremely large compared with the DC signal may erroneously produce a DC output. Therefore, if there is AC interference, the circuit should be shielded and the shield connected to the Model 197 ground (particularly for low-level sources). Improper shielding can cause the Model 197 to behave in one or more of the following ways:

1. Unexpected offset voltages.
2. Inconsistent readings between ranges.
3. Sudden shifts in reading.

To minimize pick up, keep the voltage source and the Model 197 away from strong AC magnetic sources. The voltage induced due to magnetic flux is proportional to the area of the loop formed by the input leads. Therefore, minimize the loop area of the input leads and connect each signal at only one point.

Thermal EMFs—Thermal emfs (thermoelectric potentials) are generated by thermal differences between two junction of dissimilar metals. These can be large compared to the signal which the Model 197 can measure. Thermal emfs can cause the following problems:

1. Instability or zero offset is much higher than expected.
2. The reading is sensitive to (and responds to) temperature changes. This can be demonstrated by touching the circuit, by placing a heat source near the circuit or by a regular pattern of instability (corresponding to heating and air-conditioning systems or changes in sunlight).
3. To minimize the drift caused by thermal emfs, use copper leads to connect the circuit to the Model 197. A banana plug is generally sufficient and generates just a few microvolts. A clean copper conductor such as #10 bus wire is about the best for the application. The leads to the input may be shielded or unshielded, as necessary. Refer to Shielding.
4. Widely varying temperatures within the circuit can also create thermal emfs. Therefore, maintain constant temperatures to minimize these thermal emfs. A cardboard box around the circuit under test also helps by minimizing air currents.
5. The REL control can be used to null out constant offset voltages.

2.7.6 Resistance Measurements

The Model 197 can make resistance measurements between $1\text{m}\Omega$ and $220\text{M}\Omega$. The $2\text{M}\Omega$, $20\text{M}\Omega$ and $200\text{M}\Omega$ ranges autorange when the $\text{M}\Omega$ button is selected. The Model 197 provides automatic selection of 2-terminal or 4-terminal resistance measurements. This means that if the ohms sense leads are not connected, the measurement is done 2-terminal. If the sense leads are connected the measurement is done 4-terminal. For 4-terminal measurements, rated accuracy can be obtained as long as the maximum lead resistance does not exceed the values listed in Table 2-3. For 2-terminal or 4-terminal measurements on the 200Ω range, zero must be set by the REL function to obtain rated accuracy. For best results on the 200Ω , $2\text{k}\Omega$ and $20\text{k}\Omega$ ranges, it is recommended that 4-terminal measurements be made to eliminate errors caused by the voltage drop across the test leads that occurs when 2-terminal measurements are made. To make resistance measurements, proceed as follows:

1. Connect the test leads to the HI and LO INPUT terminals. If four-wire measurements are to be made, connect an additional set of leads to the OHMS SENSE terminals.

NOTE

The Model 1641 Kelvin test lead kit is ideal for low resistance 4-terminal measurements.

2. Select the ohms function.
3. Select a range consistent with the expected resistance. If desired, use the autorange mode for automatic range selection.
4. If readings are to be made on the 200Ω range, zero the instrument to obtain rated accuracy. To zero the instrument for resistance measurements: Short the test leads together after disconnecting them from the measured circuit; if 4-wire measurements are to be made, short all four test leads as shown in Figure 2-6, allow the reading to settle then press the REL button.
5. For 2-wire measurements connect the instrument as shown in Figure 2-4. For 4-wire measurements, use the connections shown in Figure 2-5.

CAUTION

The maximum input voltage between the HI and LO INPUT terminals is 450V DC or peak AC for 10 seconds per minute, 350V RMS continuous. Do not exceed these values or instrument damage may occur. Table 2-3 shows the current output for various resistance ranges.

CAUTION

Incorrect readings will result if the resistance being measured is part of a live circuit.

6. Take the reading from the display.

Table 2-3. Resistance Ranges

Range	Resolution	I-Short	Max V Across Unknown	Maximum Test Lead Resistance for < 1 Count Error (Ω)
200	$1\text{m}\Omega$	2mA	0.5V	10
2 k	$10\text{m}\Omega$	2mA	4.0V	32
20 k	$100\text{m}\Omega$	$400\mu\text{A}$	4.0V	100
200 k	1 Ω	$40\mu\text{A}$	4.0V	320
2M	10 Ω	$4\mu\text{A}$	4.0V	1k
20M	100 Ω	400 nA	4.0V	3.2k
200M	10 k Ω	400 nA	5.0V	10k

NOTE

It is helpful to shield resistance greater than $10^6\Omega$ ($1M\Omega$) if a stable reading is expected. Place the resistance in a shielded enclosure and electrically connect the shield to the LO input terminal of the Model 197.

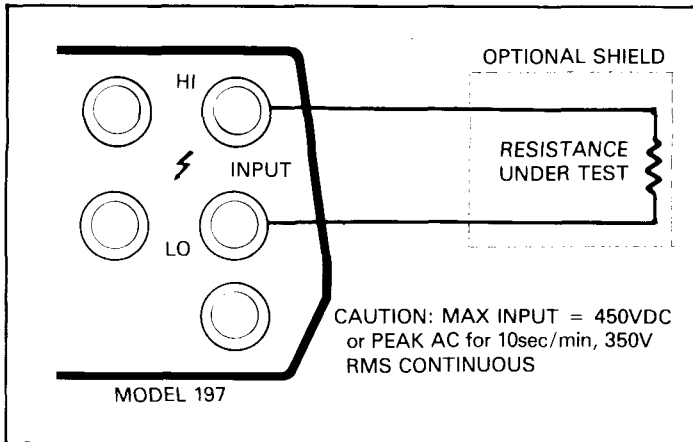

Figure 2-4. Two Terminal Resistance Measurement

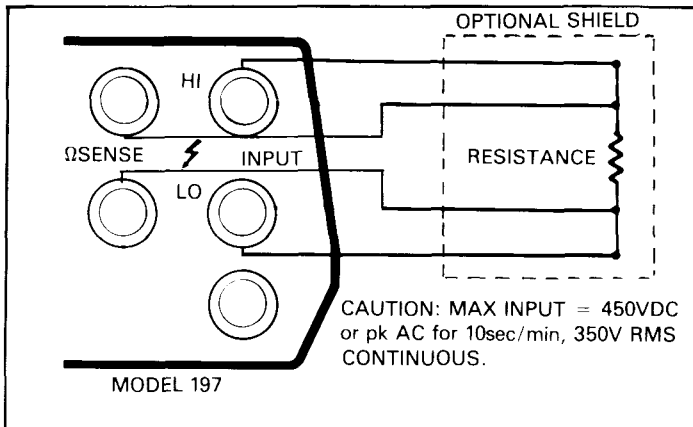

Figure 2-5. Four Terminal Resistance Measurement

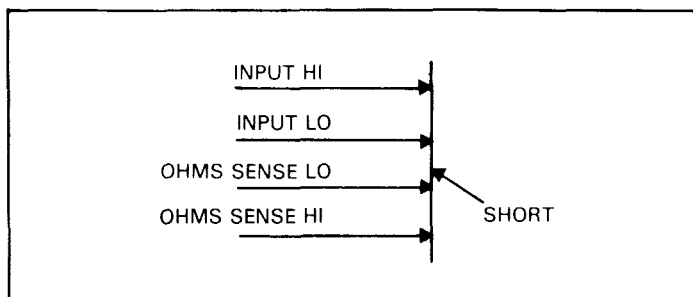

Figure 2-6. Four Terminal Zeroing

2.7.7 Current Measurements (DC or TRMS AC)

The Model 197 can make DC or TRMS AC current measurements between 1nA and 10A (20A for 15 seconds). If the expected current level is in question, make the initial measurement on the 10A range. This helps prevent inadvertent blowing of the 2A current fuse which is located on the front panel.

NOTE

For routine measurements above 10A it is recommended that the Model 1651 50A shunt be used.

1. For current measurements between 2000mA and 20A.
 - A. Connect the test leads to the 10A and LO terminals of the Model 197. Refer to Figure 2-7.

NOTE

The test leads used must be rated to handle 20A. Twist the wires as shown in Figure 2-7 to help in minimizing external fields which could affect the Model 197 or other equipment. Also, keep the test leads as short as possible to minimize voltage drop.

- B. Select the ACA or DCA function.
- C. Select the 10A range. The amps function does not autorange.
- D. Connect the test leads to the current source as shown in Figure 2-7 and take the reading from the display.

NOTE

Up to 5A may be applied continuously without degradation of the measurement due to self heating effects. Above 5A derate 0.15% rdg per amp for self heating, refer to specifications that precede Section 1. For currents between 10A and 20A, specified accuracy can only be obtained when measurements are limited to a maximum of 15 seconds.

2. For current measurements up to 2000mA:
 - A. Connect the test leads to the INPUT HI and LO terminals of the Model 197.
 - B. Select the ACA or DCA function.
 - C. Select an appropriate range for the expected current. The current function does not autorange.

- D. Connect the test leads to the current source as shown in Figure 2-8. If an overrange indication is displayed, select a higher range until a normal reading is shown. Use the lowest possible range to obtain the best resolution.
- E. Take the reading from the display.

1. Measure and record the TRMS AC component as described in paragraph 2.7.4.
2. Measure and record the DC component as described in paragraph 2.7.3.
3. Compute the rms value from the following equation:

$$E_{rms} = \sqrt{E_{DC}^2 + E_{AC}^2}$$

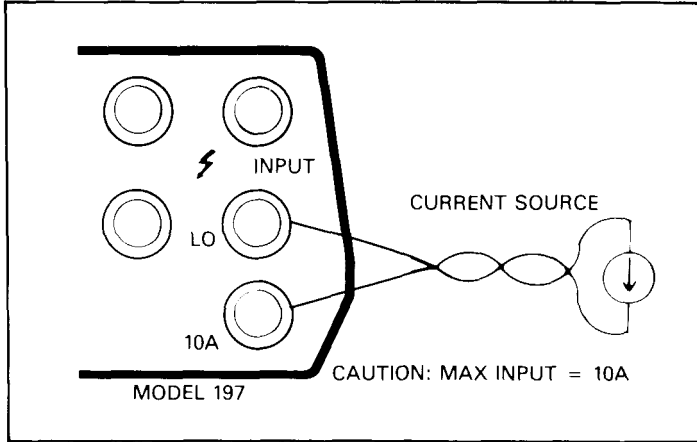

Figure 2-7. Current Measurements Between 2000mA and 20A

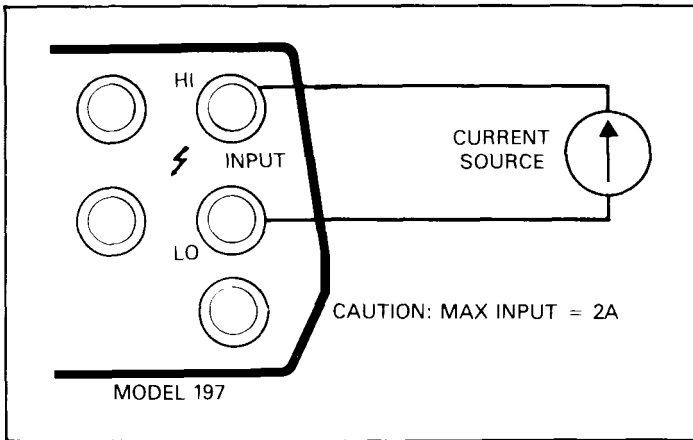

Figure 2-8. Current Measurements up to 2000mA

2.7.9 dB Measurements

The dB function makes it possible to compress a large range of readings into a much smaller scope. The relationship between dB and voltage can be expressed by the following equation.

$$dB = 20 \log \frac{V_{IN}}{V_{REF}}$$

Tables 2-4 and 2-5 list the dB specifications for DC volts and AC volts.

The Model 197 can make dB measurements referenced to the standard 600Ω impedance or to other impedances. The relative feature allows measurements in dB independent of impedance.

The basic procedure for placing the instrument in the dB mode is to first select AC or DC volts and then press the dB button. Note that once dB is selected (dB annunciator on), pressing in the Ω or A function pushbuttons will turn dB off.

Table 2-4. dB Specifications for DC Volts (600Ω Ref)

Linear Counts	Resolution	Accuracy
10-99	1dBm	± 2dBm typical
100-999	0.1dBm	± 1dBm
1000-9999	0.01dBm	± 0.1dBm
10000-220,000	0.01dBm	± 0.02dBm

2.7.8 AC Plus DC Measurements

Use the Model 197 to measure TRMS on a signal which has both AC and DC components.

Table 2-5. dB Specifications for AC Volts (600Ω Ref)

dB Mode (Ref: 600Ω)		Accuracy (± dBm)			
Range	Input	20Hz-10kHz	10kHz-20kHz	20kHz-50kHz	50kHz-100kHz
200mV	1mV to 2mV (-58 to -52dBm)	2.00	3.00	—	—
	2mV to 20mV (-52 to -32dBm)	0.85	1.10	2.00	—
	20mV to 200mV (-32 to -12dBm)	0.18	0.18	0.28	0.65
2V-750V	200mV to 750V (-12 to +59.8dBm)	0.18	0.18	0.28	0.50

dBm Measurements with 600Ω Reference Impedance

dBm is defined as decibels above or below a 1mW reference. The standard reference impedance of the Model 197 is 600Ω. What that means is that the Model 197 is designed to read 0dBm when the voltage needed to dissipate 1mW through a 600Ω impedance is applied to the Model 197. That calculated voltage level is 0.7746V as derived from the basic power equation.

$$E = \sqrt{P \cdot R}$$

$$E = \sqrt{10^{-3} \text{ W} \cdot 600\Omega}$$

$$E = 0.77456\text{V}$$

Thus with a 600Ω reference impedance the Model 197 will read 0dBm whenever 0.7746V is applied.

NOTE

Do not confuse reference impedance with input impedance. The input impedance of the instrument is not modified in the dB mode.

To make dBm measurements referenced to 600Ω, proceed as follows:

1. Connect the test leads to the INPUT HI and LO terminals of the Model 197.
2. Select the ACV or DCV function.
3. Select autorange for optimum resolution.
4. Press the dB button.
5. Connect the test leads to the voltage source.
6. Make the dBm reading from the display.

dBm Measurements with Other Reference Impedances

dBm measurements can be made with other reference impedances. The most convenient method for using other reference impedances is to algebraically subtract the calculated dB offset for the desired reference impedance from the reading on the display of the Model 197. Table 2-6 lists common reference impedances and the corresponding offset values. The following equation can be used to calculate the offset for impedances not listed in Table 2-6.

$$\text{Offset (for dBm)} = 10 \log \frac{\text{New ref } Z}{600\Omega}$$

To make dBm measurements referenced to another impedance, proceed as follows:

1. Choose the desired reference impedance.
2. Calculate or look up the offset value in Table 2-6 for the desired reference impedance.
3. Determine dBm at the desired reference impedance as follows:

$$\text{dBm (at ref } Z) = 197 \text{ reading} - \text{offset}$$

Example: Make dBm measurements referenced to a 100Ω reference impedance.

- A. 100Ω not listed in Table 2-6 so the offset must be calculated as follows:

$$\text{Offset} = 10 \log \left(\frac{100\Omega}{600\Omega} \right)$$

$$\text{Offset} = -7.78\text{dB}$$

- B. Subtract -7.78 from all subsequent displayed readings on the Model 197.

dBm measurements, referenced to another impedance, can be read directly from the display of the Model 197 by utilizing the REL feature, and an accurate voltage source. The basic procedure is as follows:

1. Calculate or look up the equivalent voltage level (Table 2-6) for 0dBm at the desired reference impedance.
2. Input that voltage level to the Model 197.
3. With the Model 197 in the dB mode, press the REL button.
4. dBm measurements referenced to the desired impedance can now be read directly from the display of the Model 197.

dBW Measurements

dBW is defined as decibels above or below a one watt reference. The procedure is the same as that found in paragraph 2.7.9 step 2. The only difference is that the reference point is 0dBW (1W) rather than 0dBm (1mW).

dBV Measurements

dBV is defined as decibels above or below 1V (0dBV point). This is a voltage relationship independent of impedance. The basic procedure is to simply subtract 2.22 dB (Table 2-6) from all subsequent displayed readings on the Model 197.

Relative dB Measurements

Just about any voltage level within the measurement limit of the Model 197 can be established as the 0dB point. The basic procedure is to establish the level as the 0dB point by using REL and make the desired dB measurements.

2.7.10 dB Measurement Considerations and Applications

1. Typical Instrument Performance

Typically, the Model 197 will perform better than its published dB specification. The following example will illustrate this point:

- A. Using the Model 197 in the dB mode (600Ω ref) measure a 1mV RMS, 1kHz source (common application in the communications field). Typically, the Model 197 will read -57.7dBm.
- B. The calculated dBm level for that source is -57.8dBm.
- C. The 0.1dBm error is considerably better than the ±2dBm specification. The specifications are intended to cover worst measurement conditions.

Table 2-6. Levels for Other Reference Impedances

Reference Impedance (Ω)	Reference Voltage Level for:		Offset (600Ω Ref)	
	0dBm	0dBW	0dBm	0dBW
8	0.0894	2.828	-18.75	11.25
50	0.2236		-10.79	
75	0.2739		-9.03	
150	0.3873		-6.02	
300	0.5477		-3.01	
600	0.7746		0.00	
1000	1.0000		2.22	

$$V_{\text{ref. for 0dBm}} = \sqrt{10^{-3}\text{W} \cdot Z_{\text{REF}}}$$

$$V_{\text{ref. for 0dBW}} = \sqrt{Z_{\text{REF}}}$$

$$\text{Offset (for dBm)} = 10 \log \left(\frac{Z_{\text{REF}}}{600\Omega} \right)$$

$$\text{Offset (for dBW)} = 10 \log \left(\frac{Z_{\text{REF}}}{600\Omega} \right) - 30\text{dB}$$

2. Measuring Circuit Gain/Loss

Any point in a circuit can be established as the 0dB point. Measurements in that circuit are then referenced to that point expressed in terms of gain (+dB) or loss (-dB). To set the 0dB point:

- A. Place the Model 197 in volts, autorange and dB.
- B. Connect the Model 197 to the desired location in the circuit.
- C. Press the REL button. The display will read 0dB.
- D. Gain/Loss measurements can now be made referenced to the 0dB point.

3. Measuring Bandwidth

The Model 197 can be used to determine the bandwidth of an amplifier as follows:

- A. Connect a signal generator to the input of the amplifier.
- B. Set the Model 197 to ACV and autorange.
- C. Connect the DMM and a frequency counter to the load of the amplifier.
- D. Adjust the frequency of the signal generator until a peak AC voltage reading is measured on the Model 197.
- E. Press the dB button and then press the REL button. The 0dB point is now established.
- F. Increase the frequency input until the Model 197 reads -3.00dB. The frequency measured on the frequency counter is the high end limit of the bandwidth.
- G. Decrease the frequency input until the dB reading again falls to -3dB. The frequency measured on the signal generator is the low end limit of the bandwidth.

4. Determining Q

The Q of a tuned circuit can be determined as follows:

A. Determine the center frequency and bandwidth as explained in paragraph 2.7.10 step 3.

B. Calculate Q by using the following formula:

$$Q = \text{Center Frequency} / \text{Bandwidth}$$

NOTE

The logging cycle can be terminated at any time by pressing the STO/CLR button. This shuts off the data logger. However, data is retained and can be recalled at any time as long as the instrument remains on. In the r=6 mode, press the RCL and the STO/CLR button to terminate the data logger cycle.

2.7.11 MIN/MAX and 100 Point Data Logger Operation

The data logger can store up to 100 readings and store the minimum and maximum readings recorded during the period that the data logger is active. The 100 points of data are stored at one of seven selectable rates from three per second to one reading per hour. Also, manual triggering is available (r=6). In the r=6 mode, one reading is stored every time the STO/CLR button is pressed. Readings for minimum and maximum are sampled at the rate of three per second regardless of the selected rate. The procedure for operating the data logger is as follows:

1. Connect the desired measurement configuration to the Model 197. Make sure that the controls of the Model 197 are set appropriately.
2. Logging Data:
 - A. Press and hold the STO/CLR button. The following reading rates will scroll on the display:
rate/meaning
r=0 (every reading)
r=1 (1 rdg/sec)
r=2 (1 rdg/10 sec)
r=3 (1 rdg/min)
r=4 (1 rdg/10 min)
r=5 (1 rdg/hour)
r=6 (1rdg every time STO/CLR is pressed)

NOTE

There is no need to select a rate if just minimum/maximum readings are desired. Press the STO/CLR button to start the logger.

- B. Release the STO/CLR button when the desired reading rate is displayed. The STO annunciator turns on and data is logged at the selected rate.
- C. In the manual trigger mode (r=6), a reading is stored every time the STO/CLR button is pressed. The following sequence takes place after the STO/CLR button is pressed when in the manual trigger mode.
 - a. The Model 197 stores the reading.
 - b. The buffer location number is briefly displayed. For example: Buffer location #1 is represented by n=01.
 - c. The Model 197 displays the applied signal and waits for the next manual trigger.

In the store mode (STO annunciator on) and when the buffer is full (100 readings stored), the minimum and maximum readings are continuously updated. When the store mode is turned off the minimum and maximum readings are not updated.

3. Data Retrieval—Data can be retrieved at any time, but a flashing RCL annunciator indicates that the maximum number of readings (100) have been stored.
 - A. Press and hold in the RCL button. The display scrolls through the data points and MIN/MAX (LO/HI). The first data point displayed is the last stored reading. The next two data points are the HI and LO readings made during that logging cycle. Notice that the longer the RCL button is held in the faster the data points scroll on the display.
 - B. Release the RCL button at the desired data point and note the reading (data) on the display. The data pointer can be incremented by steps of one by momentarily holding in the RCL button.

2.7.12 Diode Test

The 2k Ω and 200k Ω ranges can be used for testing semiconductor junctions as follows:

1. Select the ohms function.
2. Press the 2k and 200k button (diode symbols) in simultaneously.
3. Display reads forward V drop of a silicon diode at 1.6mA (1.1mA for an LED), up to 2.2V. Red terminal is positive. Accuracy is typically better than 1.5% of reading.

2.8 TRMS CONSIDERATIONS

Most DMMs actually measure the average value of an input waveform but are calibrated to read its RMS equivalent. This poses no problems as long as the waveform being measured is a pure, low distortion sine wave. For complex, nonsinusoidal waveforms, however, measurements made with an averaging type meter can be grossly inaccurate. Because of its TRMS (True Root Mean Square) measuring capabilities, the Model 197 provides accurate AC measurement for a wide variety of AC input waveforms.

2.8.1 AC Voltage Offset

Typically, the Model 197 displays 50 counts or less of offset on AC volts with the input shorted. This offset is caused by amplifier noise and offset of the TRMS converter. This offset does not affect the reading accuracy and should not be zeroed out using the REL feature. Refer to paragraph 2.7.4 step 4.

2.8.2 TRMS Measurement Comparison

The RMS value of a pure sine wave is equal to 0.707 times its peak value. The average value of such a waveform is 0.637 times the peak value. Thus, for an average-responding meter, a correction factor must be designed in. This correction factor, K, can be found by dividing the RMS value by the average value as follows:

$$K = \frac{0.707}{0.637} = 1.11$$

By applying this correction factor to an averaged reading, a typical meter can be designed to give the RMS equivalent. This works fine as long as the waveform is a pure sine wave, but the ratios between the RMS and average values of different waveforms is far from constant, and can vary considerably.

Table 2-7 shows a comparison of common types of waveforms. For reference, the first waveform is an ordinary sine wave with a peak amplitude of 10V. The average value of this voltage is 6.37V, while its RMS value is 7.07V. If we apply the 1.11 correction factor to the average reading, it can be seen that both meters will give the same reading, resulting in no error in the average type meter reading.

The situation changes with the half-wave rectified sine wave. As before, the peak value of the waveform is 10V, but the average value drops to 3.18V. The RMS value of this waveform is 5V, but the average responding meter will give 3.53V (3.18 x 1.11), creating an error of 29.4%.

A similar situation exists for the rectified square wave, which has an average value of 5V and an RMS value of 5V. Here, the average responding meter gives a reading of 5.55V (5 x 1.11), while the Model 197 gives a TRMS reading of 5V. Other waveform comparisons can be found in Table 2-7.

2.8.3 Crest Factor

The crest factor of a waveform is the ratio of its peak value to its RMS value. Thus, the crest factor specifies the dynamic range of a TRMS instrument. For sinusoidal waveforms, the crest factor is 1.414. For a symmetrical square wave, the crest factor is unity.

The crest factor of other waveforms will, of course, depend on the waveform in question because the ratio of peak to RMS value varies. For example, the crest factor of a rectangular pulse is related to its duty cycle; as the duty cycle decreases, the crest factor increases. The Model 197 has a crest factor of 3, which means the instrument gives accurate TRMS measurements of rectangular waveforms with duty cycles as low as 10%.

2.8.4 Extended Frequency Response

Figure 2-9 illustrates the extended frequency response of the ACV ranges up to 1MHz.

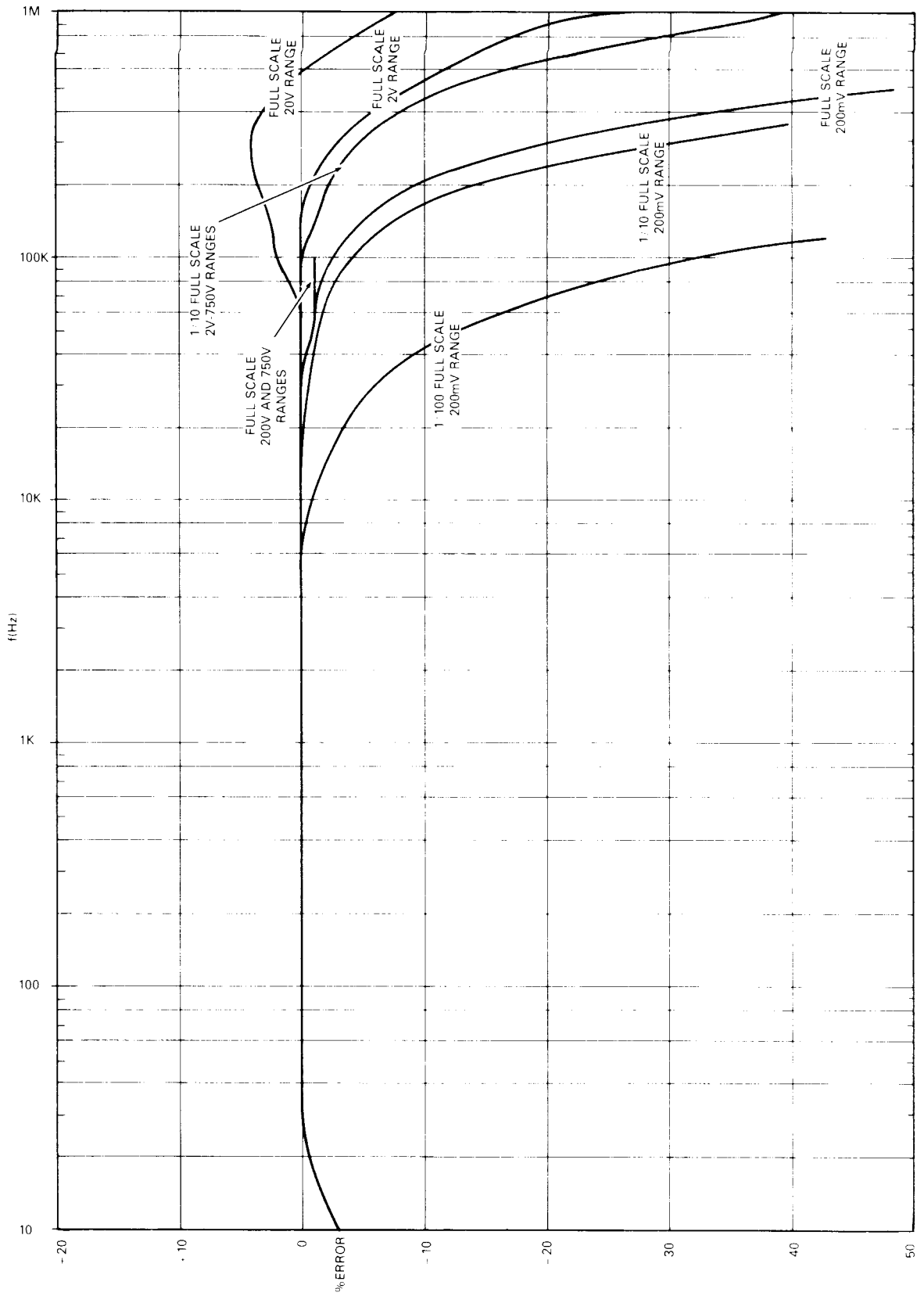
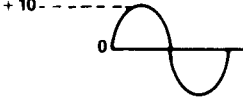
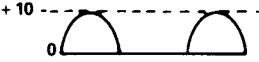

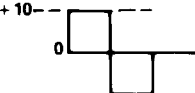

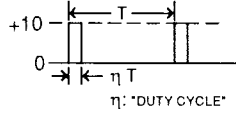
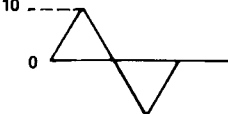

Figure 2-9. Typical ACV Frequency Response

Table 2-7. Comparison of Average and TRMS Meter Readings

Waveform	Ac Coupled Peak Value	RMS Value	Average Responding Meter Reading	Ac Coupled TRMS Meter Reading	Averaging Meter Percent Error
Sine 	10V	7.07V	7.07V	7.07V	0%
Half-Wave Rectified Sine 	10V	5.00V	3.53V	5.00V	29.4%
Full-Wave Rectified Sine 	10V	7.07V	7.07V	7.07V	0%
Square 	10V	10.00V	11.10V	10.00V	11%
Rectified Square Wave 	10V	5.00V	5.55V	5.00V	11%
Rectangular Pulse 	10V	$10V \cdot \sqrt{\eta}$	$11.1V \cdot \eta$	$10V \cdot \sqrt{\eta}$	$(1.11 \sqrt{\eta} - 1) \times 100\%$
Triangular Sawtooth 	10V	5.77V	5.55V	5.77V	3.8%

SECTION 3 PERFORMANCE VERIFICATION

3.1 INTRODUCTION

This section contains information necessary to verify that the Model 197's performance is within specified accuracy. Model 197 specifications may be found at the front of this manual. Ideally, performance verification should be performed when the instrument is first received to ensure that no damage or change in calibration has occurred during shipment. The verification procedure may also be performed whenever instrument accuracy is suspect or following calibration. If performance on any of the ranges or functions is inconsistent with specifications, calibration should be performed as described in Section 5.

NOTE

If the instrument does not meet specifications and it is still under warranty (less than 12 months since date of shipment), contact your Keithley representative or the factory to determine the action to be taken.

3.2 ENVIRONMENTAL CONDITIONS

All measurements should be made at an ambient temperature between 18°C and 28°C (65°F to 82°F) with a relative humidity less than 80%.

3.3 RECOMMENDED TEST EQUIPMENT

Equipment for verifying the performance of the Model 197 is listed in Table 3-1. Alternate equipment may be used as long as equipment accuracy is at least equal to the specifications listed in Table 3-1.

3.4 INITIAL CONDITIONS

Before performing the verification procedures, make sure the Model 197 meets the following conditions:

1. If the instrument has been subjected to temperature below 18°C (65°F) or above 28°C (82°F), allow sufficient time for the instrument to reach temperatures within the range. Generally, it takes one hour to stabilize an instrument that is 10°C (18°F) outside of this range.
2. Turn on the Model 197 and allow it to warm up for one hour. The instrument may be operated from either line power or battery pack power, as long as the battery pack has been fully charged as described in paragraph 2.3.3.

3.5 VERIFICATION PROCEDURE

The following paragraphs give the basic verification procedure for the following functions DC volts, AC volts, resistance and current.

Table 3-1. Equipment Specifications

Mfg	Model	Description	Specifications
Fluke	343A	DC Voltage Calibrator	200mV, 2V, 20V, 200V, 1000V ranges $\pm 0.005\%$
Fluke	5200A	AC Voltage Calibrator	200mV, 2V, 20V, 100V 50Hz to 10kHz $\pm 0.05\%$
Valhalla	2500E	AC-DC Current Calibrator	200 μ A, 2mA, 20mA, 200mA, 2000mA, 10A ranges $\pm 0.03\%$ DC, $\pm 0.1\%$ AC to 5kHz (at full scale)
Fluke	5450A	Resistance Calibrator	100 Ω , 1k Ω , 10k Ω , 100k Ω ranges $\pm 0.005\%$; 1M Ω range $\pm 0.01\%$; 10M Ω range $\pm 0.05\%$; 100M Ω $\pm 0.5\%$
Fluke	5215A	Power Amplifier	1000V range: 10Hz-30Hz $\pm 0.12\%$; 50kHz-100kHz $\pm 0.10\%$; 100V max @ 100kHz = 10 ⁷ VHz; 750V max @ ≈ 13 kHz = 10 ⁷ VHz

WARNING

The following procedures require that high voltages may be applied to the input terminals of the Model 197. Use normal safety precautions to avoid possible electrical shock which could result in personal injury or death.

3.5.1 DC Voltage Accuracy Check

1. Select the DC volt function and autorange.

CAUTION

Do not exceed 1000V between the input HI and LO terminals or damage to the instrument may occur.

2. Connect the calibrator to the instrument as shown in Figure 3-1.
3. Set the calibrator to 0V and enable the relative mode. Leave the relative mode enabled for all DCV measurements. Check to see that the reading is 000.000V ± 1 count.
4. Apply a positive 200mV to the HI and LO INPUT terminals. The reading must be within the limits specified in Table 3-2.
5. For each remaining range, apply the required voltage as specified in Table 3-2 and verify that the reading is within specifications.
6. Repeat all checks with negative voltage.

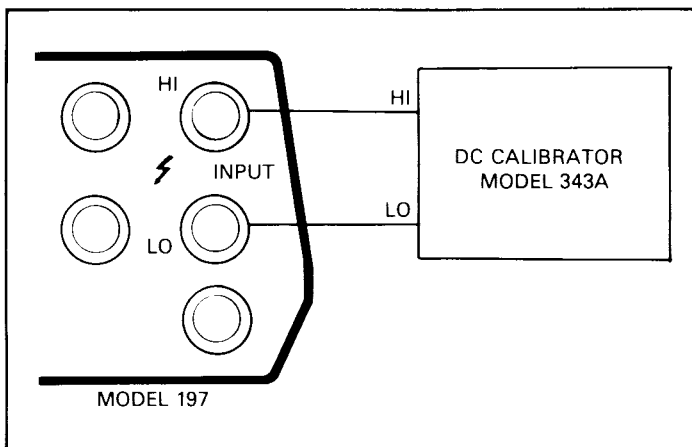

Figure 3-1. Connections for DCV Verification

Table 3-2. Limits for DC Voltage Verification

197 DCV Range	Applied DC Voltage	Allowable Readings* (18°C to 28°C)
200mV	200.000mV	199.965 to 200.035
2 V	2.00000 V	1.99976 to 2.00024
20 V	20.0000 V	19.9968 to 20.0032
200 V	200.000 V	199.968 to 200.032
1000 V	1000.00 V	999.68 to 1000.32

*The limits shown do not include test equipment tolerances.

3.5.2 AC Voltage Accuracy Check

CAUTION

Do not exceed 750V RMS, 1000V peak 107VHz between HI and LO INPUT terminals or instrument damage may occur.

1. Select the AC volts function and autorange. Do not use REL to zero the offset in this procedure. Refer to paragraph 2.7.4 step 4.
2. Connect the AC calibrator to the HI and LO INPUT terminals of the Model 197 as shown in Figure 3-2.
3. Set the calibrator to output 2.00000V at a frequency of 50Hz. Verify that the reading is within the limits specified in Table 3-3.
4. Repeat the 2.00000V AC measurement at the other frequencies specified in Table 3-3.
5. Check the 20V, 200V and 750V ranges by applying the required voltage and frequencies specified in Table 3-3 and verifying that the readings are within the specified limits.

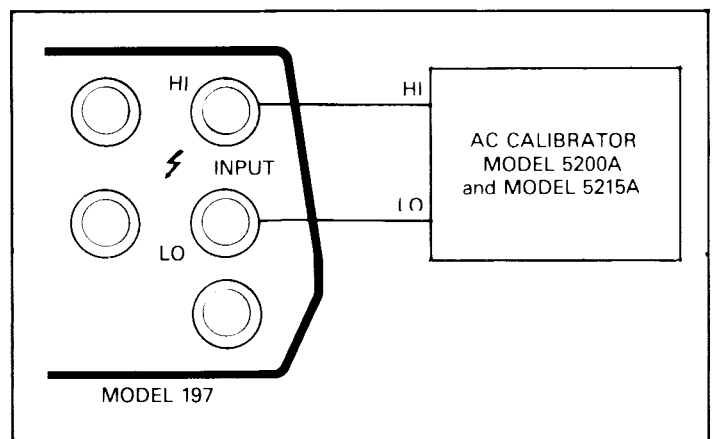

Figure 3-2. Connections for ACV Verification

Table 3-3. Limits for AC Voltage Verification

197 AC Range	Applied AC Voltage	20Hz	50Hz	10kHz	20kHz	50kHz	100kHz
200mV	200.000mV	197.900 to 202.100	199.200 to 200.800	198.600 to 201.400	196.750 to 203.250	189.600 to 210.400	189.600 to 210.400
2 V	2.00000V	1.97900 to 2.02100	1.99200 to 2.00800	1.98600 to 2.01400	1.96750 to 2.03250	1.93600 to 2.06400	1.93600 to 2.06400
20 V	20.0000V	19.7900 to 20.2100	19.9200 to 20.0800	19.98600 to 20.1400	19.6750 to 20.3250	19.3600 to 20.6400	19.3600 to 20.6400
200 V	200.000V	197.900 to 202.100	199.200 to 200.800	199.860 to 201.400	196.750 to 203.250	193.600 to 206.400	
750 V	750.000V	739.63 to 760.37	743.37 to 755.62	740.50 to 759.50			

3.5.3 Resistance Accuracy Check

Resistance verification is performed by connecting known, precise resistance values to the HI and LO input terminals and checking to see that the displayed reading is within the required limits. Measurements on the 200Ω, 2kΩ and 20kΩ ranges will be done using the 4-terminal configuration to minimize errors due to the voltage drop across the test leads.

CAUTION

Do not exceed 450VDC or peak AC for 10 seconds per minute, 350V rms continuous between the HI and LO INPUT terminals or the instrument might be damaged.

1. Select the ohms function (AC/DC button must be out) and the 200Ω range.
2. Use Kelvin test leads (e.g. Keithley Model 1641) in the input HI and LO, and then OHMS SENSE HI and LO terminals. Short the leads together. Enable the relative (REL) mode. Check to see that the display reads 000.000. Leave the relative mode enabled for the remaining resistance measurements.
3. Connect a 190Ω calibration resistor as shown in Figure 3-3. Note that the 4-terminal configuration is used for this measurement.
4. Check to see that the displayed reading is within the limits specified in Table 3-4.

5. Connect a 1.9kΩ calibration resistor to the instrument as shown in Figure 3-3. Switch the instrument to the 2kΩ range. Verify that the displayed reading is within the limits specified in Table 3-4.
6. Connect a 19kΩ calibration resistor to the instrument as shown in Figure 3-3. Switch the instrument to the 20kΩ range. Verify that the displayed reading is within the limits specified in Table 3-4.
7. Connect a 190kΩ calibration resistor to the instrument as shown in Figure 3-4. Switch the instrument to the 200kΩ range. Verify that the displayed reading is within the limits specified in Table 3-4. Note that the 2-terminal configuration may be used on the 200kΩ and higher ranges.
8. Continue with each of the calibration resistance values listed in Table 3-4. Be sure to place the Model 197 on the correct range for each measurement. The remaining readings may be done using 2-terminal configuration.

Table 3-4. Limits for Resistance Verification

197 Range	Applied Resistance	Allowable Readings (18°C to 28°C)
200	190.000 Ω	189.959 to 190.041
2 k	1.90000 kΩ	1.89964 to 1.90036
20 k	19.0000 kΩ	18.9949 to 19.0051
200 k	190.000 kΩ	189.949 to 190.051
2M	1.90000MΩ	1.89931 to 1.90069
20M	19.0000MΩ	18.9770 to 19.0230
200M	190.000MΩ	186.199 to 193.801

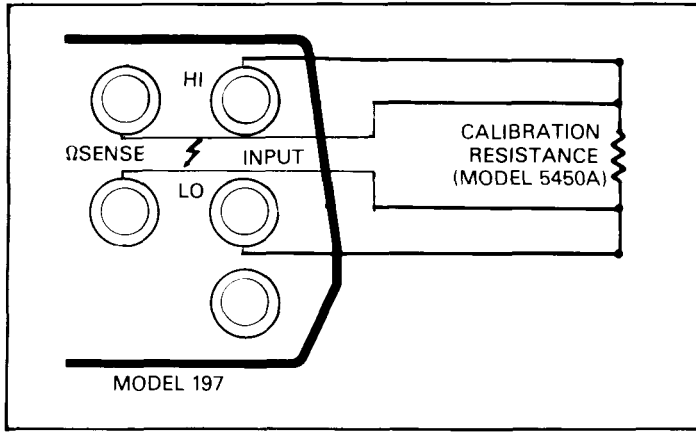

Figure 3-3. Connections for 200, 2k and 20k Range Verification (4-terminal)

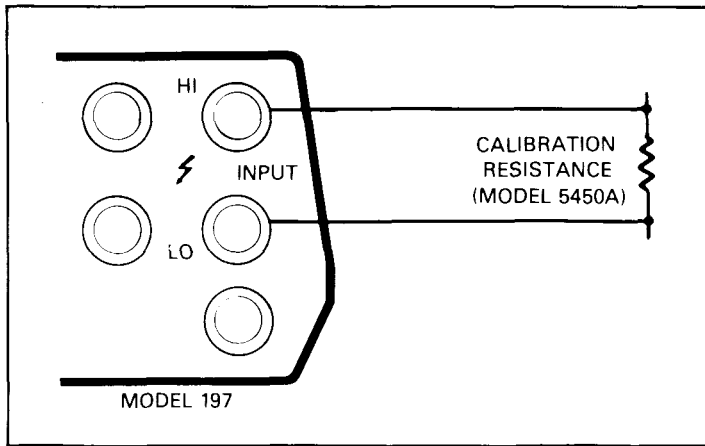

Figure 3-4. Connections for 200k through MΩ Ranges Verification (2-Terminal)

3.5.4 DC Current Accuracy Check

DC current accuracy is checked by connecting a calibrated DC current source to the HI and LO INPUT terminals for up to 2000mA (10A and LO terminals for 2000mA through 10A). The accuracy is then verified by referring to Table 3-5 which shows the exact number of counts allowable in order to remain in the limit of the specifications.

CAUTION

Do not exceed 2A to the HI and LO INPUT terminals or the front panel amps fuse will blow. Refer to paragraph 2.4.4.

1. Select the DC current function. Select the 2000mA range.
2. Connect the instrument to the DC current calibrator as shown in Figure 3-5. The HI side of the AMPS terminal should be connected to the HI terminal and the LO side of the calibrator output should be connected to LO.
3. Set the calibrator to 00.000 and enable the realtive (REL) mode.
4. Verify that the displayed reading is within the limits specified in Table 3-5.
5. Switch the Model 197 to the 20mA range. Set the calibrator to output +20.0000mA. Verify that the displayed reading is within the limits specified in Table 3-5.
6. Switch the Model 197 to the 200mA range. Set the calibrator to output +200.000mA. Verify that the displayed reading is within the limits specified in Table 3-5.
7. Switch the Model 197 to the 2000mA range. Set the calibrator output +2000.00mA. Verify that the reading is within the limits specified in Table 3-5.
8. Set the Model 197 to the 10A range. Connect the DC current to the 10A and LO terminal as shown in Figure 3-6.

NOTE

Be sure to connect the calibrator to the 10A and LO terminals. Otherwise, applying the 5A (as specified in Table 3-5) would blow the front panel current fuse.

9. Apply +0.50000VDC to the current calibrator to output 5.0000A. Verify that the reading is within the limits specified in Table 3-5.
10. Repeat steps 1 through 10 with negative current.

Table 3-5. Limits for DC Current Verification

197 DC Range	Applied DC Current	Allowable Readings (18°C to 29°C)
200 μ A	200.000 μ A	199.785 to 200.215
2mA	2.00000mA	1.99785 to 2.00215
20mA	20.0000mA	19.9785 to 20.0215
200mA	200.000mA	199.585 to 200.415
2000mA	2000.00mA	1995.85 to 2004.15
10 A	5.0000 A	4.9610 to 5.0390

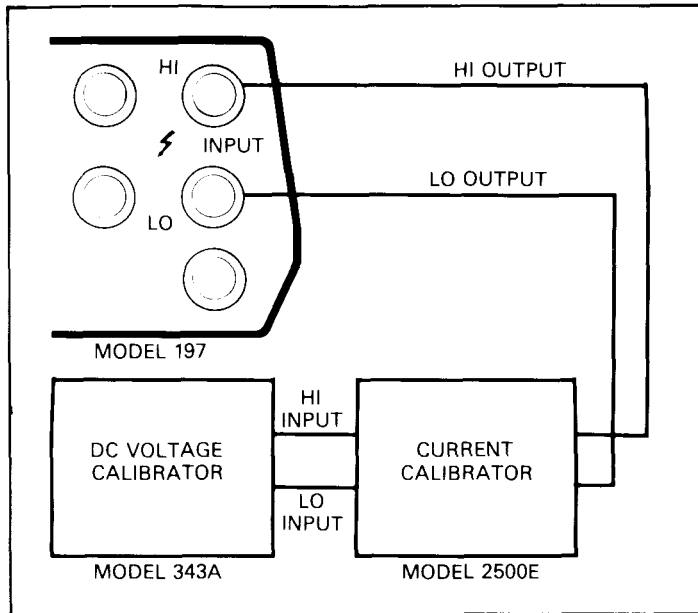

Figure 3-5. Connections for DC Current Verification (200 μ A to 2000mA)

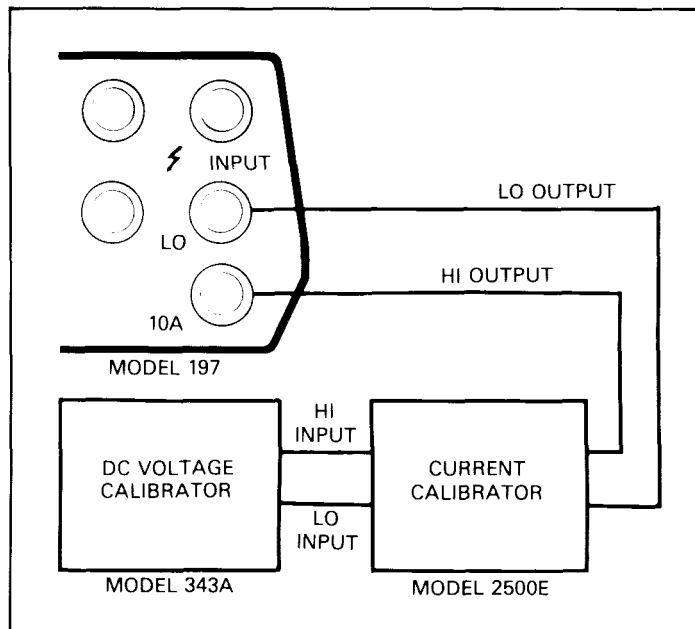

Figure 3-6. Connections for DC Current Verification (2000mA to 20A)

3.5.5 AC Current Accuracy Check

AC current accuracy is checked by connecting a calibrated AC current source to the HI and LO INPUT terminals for 200 μ A to 2000mA, 10A and LO terminals for 2000mA to 20A, and then verifying that the displayed reading is within the specified range.

CAUTION

Do not exceed 2A between the HI and LO INPUT terminals or instrument damage might occur. Refer to paragraph 2.4.4.

1. Select the AC current function on the Model 197. Place the instrument in the 2000mA range.
2. Connect the AC calibrator to the Model 197 as shown in Figure 3-7. Set the calibrator frequency to 1kHz. Do not use the relative mode to zero the offset in the AC mode.
3. Set the calibrator to output 200.000 μ A and switch the Model 197 to the 200 μ A range. Verify that the displayed reading is within the limits specified in Table 3-6.
4. Change the Model 197 to the 2mA range. Set the calibrator to output 2.00000mA. Verify that the displayed reading is within the limits specified in Table 3-6.
5. Change the Model 197 to the 20mA range. Set the calibrator to output 20.0000mA. Verify that the displayed reading is within the limits specified in Table 3-6.
6. Change the Model 197 to the 200mA range. Set the calibrator to output 200.000mA. Verify that the displayed reading is within the limits specified in Table 3-6.
7. Change the Model 197 to the 2000mA range. Set the calibrator to output 2000.00mA. Verify that the displayed reading is within the limits specified in Table 3-6.
8. Connect the calibrator to the Model 197 10A and LO terminals as shown in Figure 3-8. Change the Model 197 to the 10A range.

NOTE

Be sure to connect the calibrator to the 10A and LO terminals. Otherwise, applying the 5A (as specified in Table 3-6) would blow the front panel current fuse.

9. Set the calibrator to output 5.0000A. Verify that the displayed reading is within the limits specified in Table 3-6.

Table 3-6. Limits for AC Current Verification

197 AC Range	Applied AC Current	20Hz	50Hz	5kHz
200 μ A	200.000 μ A	197.900 to 202.100	198.300 to 201.700	195.750 to 204.250
2mA	2.00000mA	1.97900 to 2.02100	1.98300 to 2.01700	1.95750 to 2.04250
20mA	20.0000mA	19.7900 to 20.2100	19.8300 to 20.1700	19.5750 to 20.4250
200mA	200.000mA	197.900 to 202.100	198.300 to 201.700	198.270 to 201.730
2000mA	2000mA	1979.00 to 2021.00	1983.00 to 2017.00	1982.70 to 2017.30
10 A	5.0000 A	4.9150 to 5.0850	4.9400 to 5.0600	4.9400* to 5.0600

*Not to exceed 1kHz.

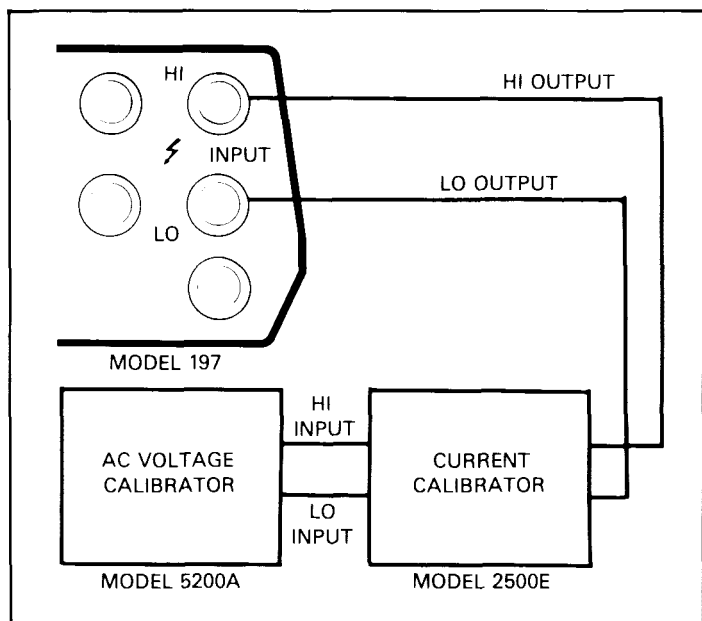

Figure 3-7. Connections for AC Current Verification (200 μ A to 2000mA)

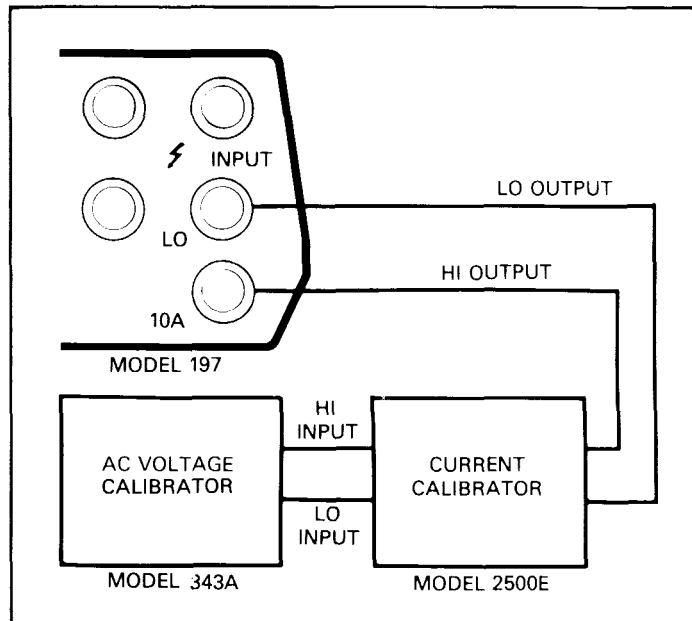

Figure 3-8. Connections for AC Current Verification (2000mA to 10A)

SECTION 4

THEORY OF OPERATION

4.1 INTRODUCTION

This section contains an overall functional description of the Model 197. Information pertaining to the Model 1978 Battery Pack option is also included. Detailed schematics and component layout drawings are located at the end of this instruction manual.

4.2 OVERALL FUNCTIONAL DESCRIPTION

The Model 197 is a 5½ digit DMM with five AC and DC voltage ranges, seven resistance ranges and six AC and DC current ranges. A simplified block diagram of the Model 197 is shown in Figure 4-1. The heart of the Model 197 is the A/D converter that translates the conditioned analog input signal into a form usable by the microcomputer.

4.3 ANALOG CIRCUITRY

The following paragraphs contain a description of the input multiplexer, buffer amplifier, +2V reference and A/D converter circuits. These circuits may be found on schematic diagram number 197-106 located at the end of this manual.

4.3.1 Multiplexer

The multiplexer connects one of four signals to the buffer amplifier: signal, zero, reference and ohms reference. The multiplexer, shown in Figure 4-2, is made up of 4 JFETs which are controlled by the microprocessor through U114. The FETs are driven by drivers U103 and U112. The drivers convert the digital signals of the microprocessor to signals usable by the FETs.

Note that the particular FET used to sense zero on DCV is range dependent. This is done so that zero may be sensed in a manner that eliminates the errors due to the ON resistances of Q106 and Q109. It also reduces errors due to leakage current of U102.

Ordinarily, FET switching creates transients which could be seen in the final measurement. These effects are minimized in the Model 197 through the use of software generated delays.

4.3.2 Input Buffer Amplifier

The input buffer amplifier provides the necessary isolation between the input signal and the A/D converter. The amplifier is a noninverting, low noise, high impedance circuit with X1 or X10 gain. The amplifier gain is controlled by the microprocessor and is range and function dependent. Figure 4-3 shows the simplified schematic of the input buffer amplifier. The gain is X10 when Q116 is ON and X1 when Q116 is OFF.

4.3.3 2V Reference Source

The Model 197 voltage and current measurements are based on comparing the unknown signal with an internal 2V reference voltage. During each measurement cycle the unknown is sampled along with a zero measurement and a 2V reference measurement to compute the unknown voltage.

The 2V reference is made up of a highly stable zener diode (VR103), an op-amp and a resistive divider. U109 and R125C, D, and E act as a constant current source to minimize the zener voltage variations. R121D, E and F is then used to divide down the 6.4V zener voltage to 2V.

The output of U109 is buffered by Q122 to form a +10V supply.

4.3.4 Input Signal Conditioning

For DCV and ACV the signal conditioning is performed by R103, R104, R105 and their shunt capacitors. Range switching is performed by K101, K102, K103, Q105, Q106 and Q109. Q107 and Q108 are used to sense zero in a manner that eliminates the errors due to the on resistances of Q106 and Q109. The FETs are driven by U112.

The following attenuation is provided:

- ÷1 is used on the 200mV and 2V ranges.
- ÷10 is used on the 20V range.
- ÷100 is used on the 200V range.
- ÷1000 is used on the 1000V/750V range.

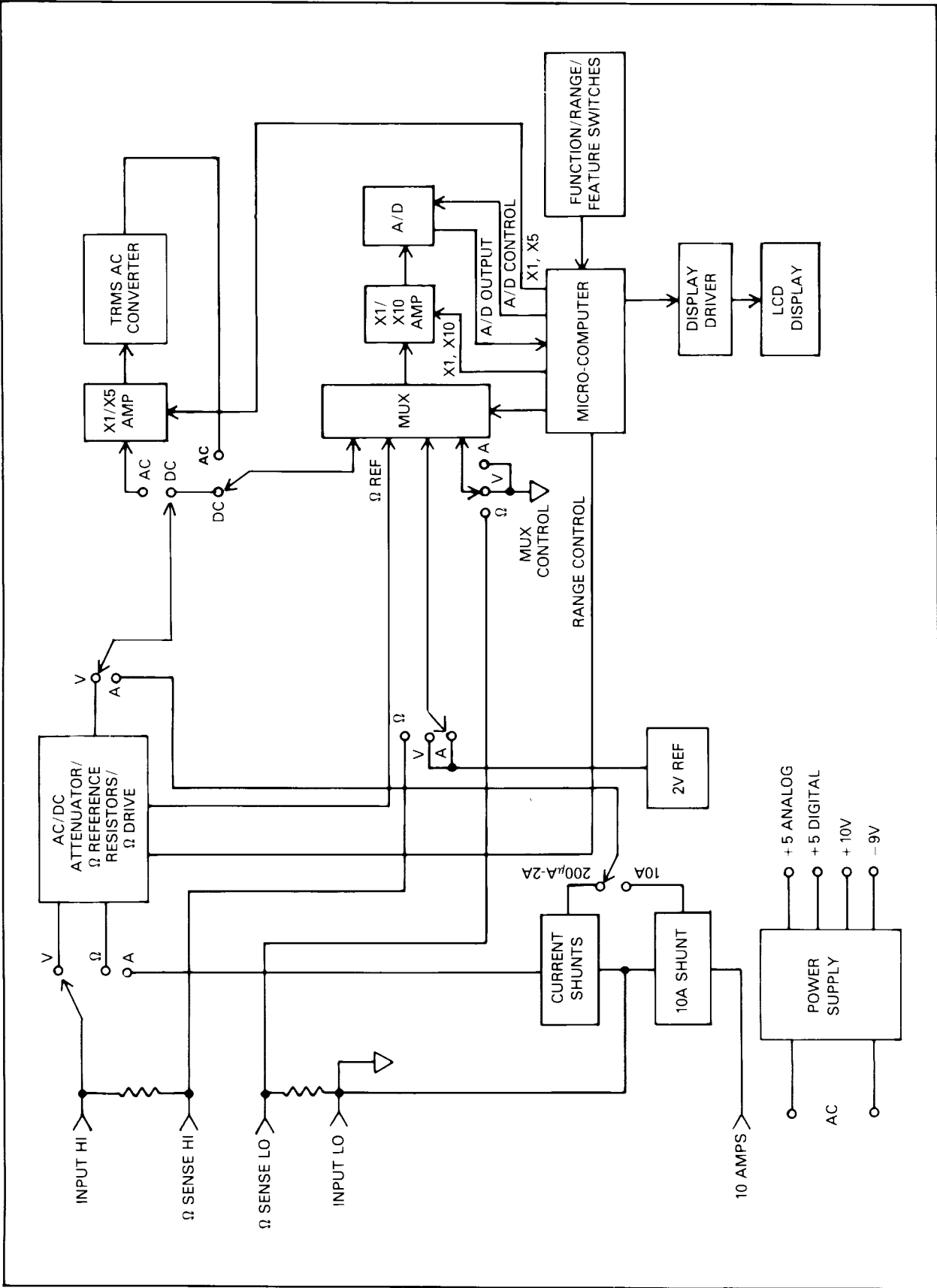

Figure 4-1. Simplified Block Diagram

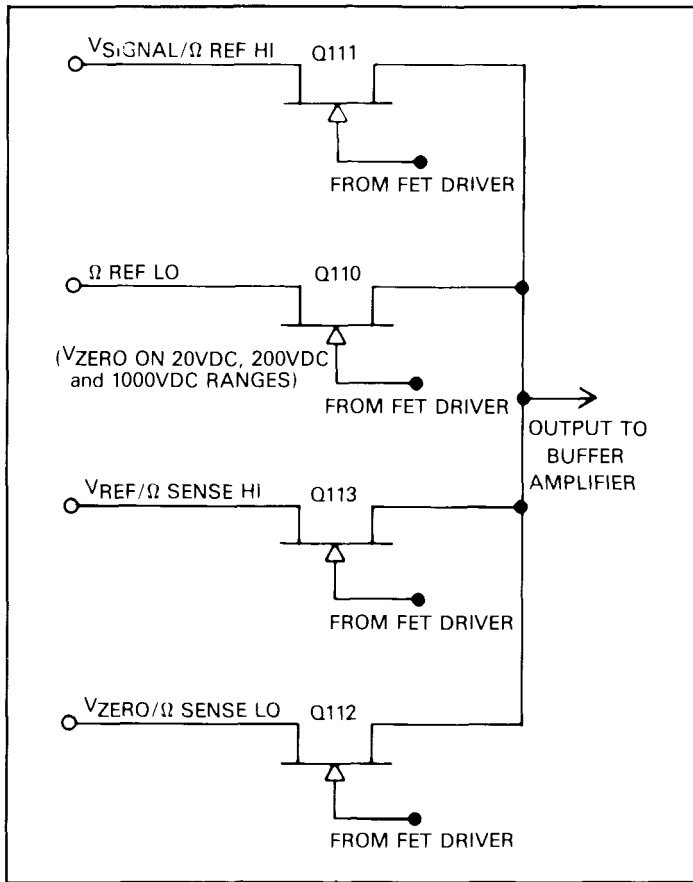

Figure 4-2. JFET Multiplexer

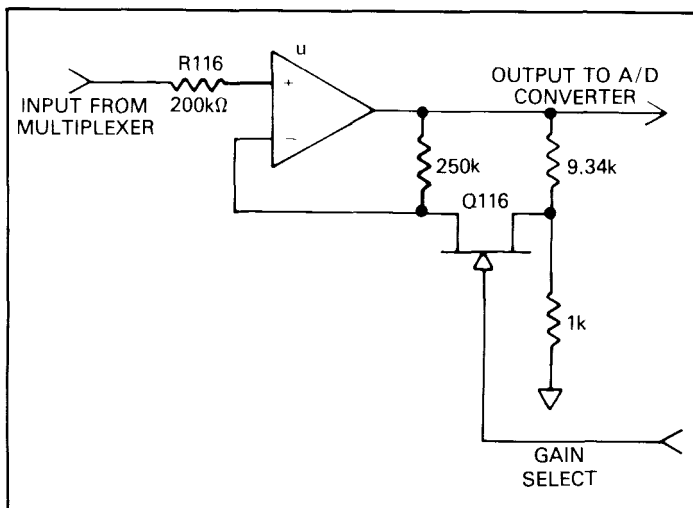

Figure 4-3. Simplified Schematic of the Input Buffer Amplifier

Protection for the AC and DC voltage functions is provided by Q103, Q127, Q114, Q115, CR102, CR104, R106, R107

and R113. R106 and R107 are used exclusively on the 200mV and 2V ranges of DCV to limit current to Q114 and Q115. R113 is used exclusively on the 200mV and 2V ranges of ACV to limit current to CR102 and CR104.

Signal conditioning for current is performed by R112, R118 and R123 current shunts. For DC current measurements the shunt voltage drop (220mV full range) is applied directly to the input signal FET for conversion. In AC current, the shunt voltage drop is treated as a <220mV AC signal and is switched to the AC converter section. Overload clamping occurs at 3 diode drops which is a level high enough to permit high crest factor current waveforms.

In DCV the properly scaled signal is applied directly to Q111 through R106, R107 and C109. In ACV the scaled signal is applied to the AC converter for transformation to a DC signal that is applied to Q111.

Resistance measurements are made using the ratiometric technique (see Figure 4-4). When the resistance function is selected, a series circuit is formed between the ohms source, a reference resistor, and the external unknown resistance. An ohms source of 4.3V is obtained by placing a protection diode (CR101) in series with a +5V supply and the ratiometric network. A current then flows through the reference resistor and the unknown resistance. Since this current is common to both resistances, the value of the unknown resistance can be calculated by measuring the voltage across the reference resistor and the voltage across the unknown resistance.

The following ohms reference resistors are used (see Figure 4-5).

- R103||R105A||R105B (1kΩ) on 200Ω and 2kΩ ranges
- R105D||R105A||R105B (10kΩ) on 20kΩ range
- R105C||R105A||R105B (100kΩ) on 200kΩ range
- R105A||R105B (1MΩ) on 2MΩ range
- R105A (10MΩ) on 20MΩ and 200MΩ ranges

By measuring the four inputs to the A/D converter the unknown resistance can be computed by the microprocessor using this equation:

$$R_X = \frac{R_{REF} \cdot (V_{\Omega \text{ SENSE HI}} - V_{\Omega \text{ SENSE LO}})}{V_{\Omega \text{ REF HI}} - V_{\Omega \text{ REF LO}}}$$

For the 200Ω range VΩ SENSE HI and VΩ SENSE LO are actually multiplied by a factor of 10 in the buffer circuit.

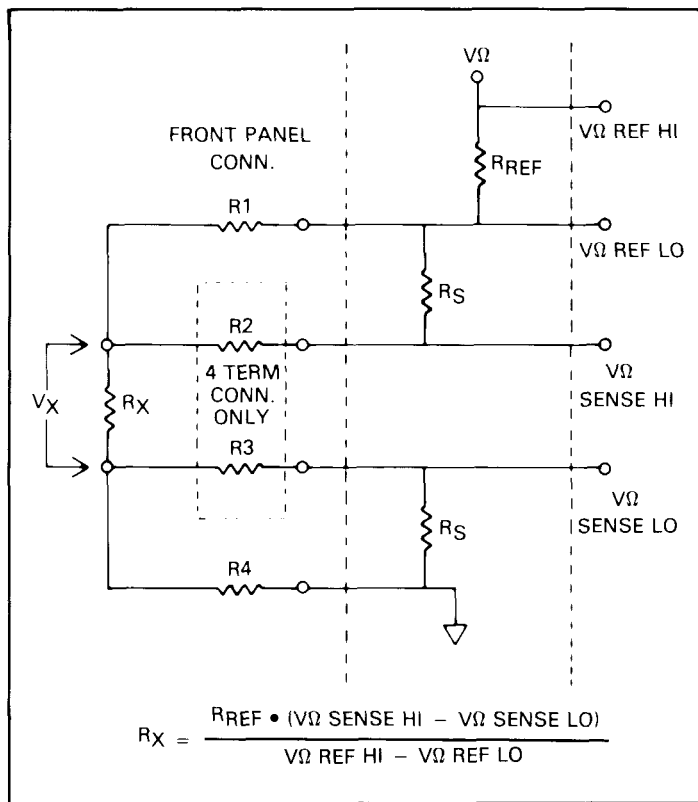

Figure 4-4. Input Configuration During 2- and 4-Terminal Resistance Measurements

Protection on the ohms ranges is accomplished by RT101, Q101 and Q102. For an input voltage applied to the Ω input terminals, Q101 and Q102 clamp the voltage to the reference resistors to a safe limit. RT101 limits the current to Q101 and Q102. R105A provides protection of the ohms source by limiting current.

The Model 197 is equipped to make 2- or 4-terminal resistance measurements. Generally, 4-terminal measurements should be made on the 200 Ω range because the relatively large output current can develop a significant voltage across the test leads, affecting instrument accuracy.

Figure 4-4 shows the equivalent circuit of the input circuit. R_X is the unknown measured resistance and R1, R2, R3 and R4 represent the test lead resistance. R2 and R3 are connected only during 4-terminal measurements. When using a 2-terminal configuration, all the current flows through the test leads R1 and R4. If R_X has a low value, the amount of voltage developed across the test leads can be significant. Since the voltage is sensed across the combined resistance of R_1 , R_X and R_4 ; considerable error can be introduced into the reading. To use a 4-terminal connection, a second set of leads (R2 and R3) are connected to the unknown resistance. The amount of

current through R2 and R3 is much smaller than the current through R1 and R4. Thus, the voltage seen by the instrument is much closer to the actual value across the measured resistance, minimizing the error.

4.3.5 A/D Converter

The Model 197 uses a combination constant frequency variable pulse width, charge balance, single slope analog-to-digital converter. A simplified schematic of the A/D used in the Model 197 is shown in Figure 4-4 with an associated waveform. Refer to schematic 197-106 for detailed component location.

The charge balance phase begins when the input enable/disable line is set high. This occurs at the end of a software-generated delay period that allows the signal to settle after the appropriate multiplexer FET is turned on.

Once this occurs, an offset is added to the signal from the buffer to convert it to a negative unipolar input to the integrator. The signal from the buffer has a range of $-2.2V$ to $+2.2V$ on the volts and amps functions, and $0V$ to $+4V$ on the ohms function. Therefore, it is necessary to have a larger offset on the ohms function. This is done by switching in R117B.

The integrator (comprised of Q121, U110 and C123) ramps up until it just passes the charge-balance comparator threshold voltage. When the rising edge of Q3 (U119) occur Q1 of U117A goes high forcing I_{CB} into the integrator input. The time Q1 of U117A remains high depends upon the state of comparator U108B when Q3 (U119) goes high. Thus, the amount of I_{CB} fed back to the integrator input will be proportional to the input voltage. Each time the output U117A goes high it is gated (inside the microprocessor) with the microprocessor's internal clock and pulses are counted. Once U117A goes low the process repeats itself.

The charge balance phase continues for 100msec. At the end of the charge balance phase, the output of the integrator is resting at some positive voltage. Since the integrator output is connected to the noninverting input of the U108A, its output will stay high until the integrator ramps negative. During single slope Q120 is turned off and R129 is connected to $+5V$. The single slope comparator is then gated with the microprocessor's internal clock and counted. Once the comparator output goes low the microprocessor stops counting and can compute the reading.

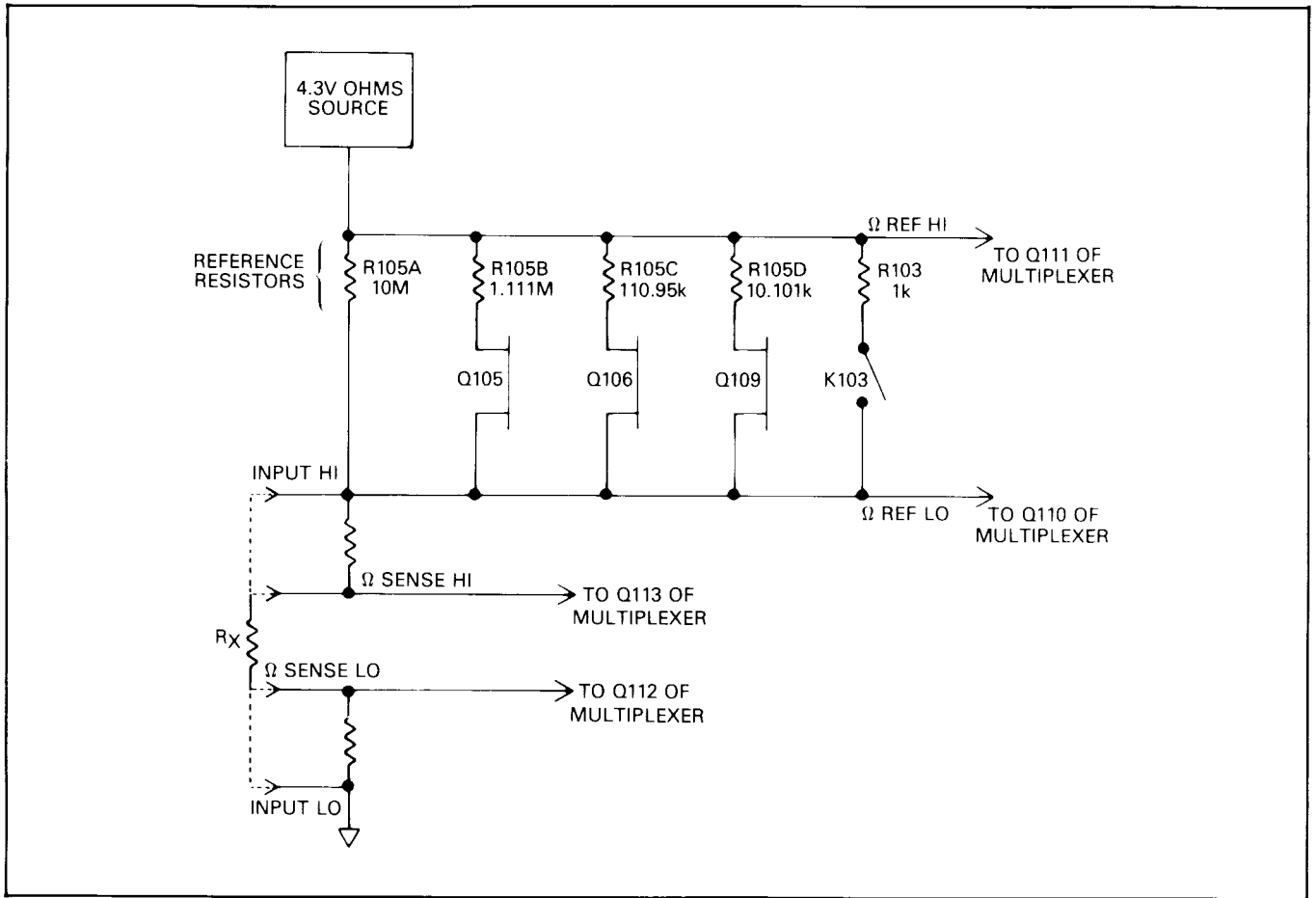

Figure 4-5. Resistance Measurement Simplified Circuit

4.3.6 AC Converter

On the 200mV AC range the input is routed through U104 for a X5 voltage amplification. The gain stage is used to permit accurate voltage measurements at higher frequencies and lower input levels. On all other ranges U104 is configured for a gain of X1. The gain of U104 is controlled by the microprocessor. The output of U104 is applied to the TRMS converter chip, U106, which converts the AC input signal to the corresponding DC level. The DC output is then applied to the signal FET.

4.4 DIGITAL CIRCUITRY

Model 197 operation is controlled by the internal microcomputer. This section briefly describes the operation of the various sections of the microcomputer and associated digital circuitry. For more complete circuit details refer to schematic diagram number 197-106 at the end of this manual.

4.4.1 Microcomputer

The microcomputer centers around the 146805E2 CMOS microprocessor. It is an 8 bit microprocessor with direct addressing of up to 8k bytes on a shared address and data bus.

Timing of the microprocessor is accomplished by the use of Y101; a 3.2768MHz crystal. Internally this frequency is divided down by 5 to obtain a bus operating frequency of 655.36kHz. This is present on the address strobe of U124 (pin 6) and supplies timing to all other parts of the instrument through the binary divider U119.

The software for the MPU is stored in U122 (PROM). Temporary storage is provided by U121. U121 is used to share the calibration constants on power up and as RAM for the microprocessor's in-house functions. It also stores readings for the data logger. U113 is the NVRAM and is used to store the calibration constants.

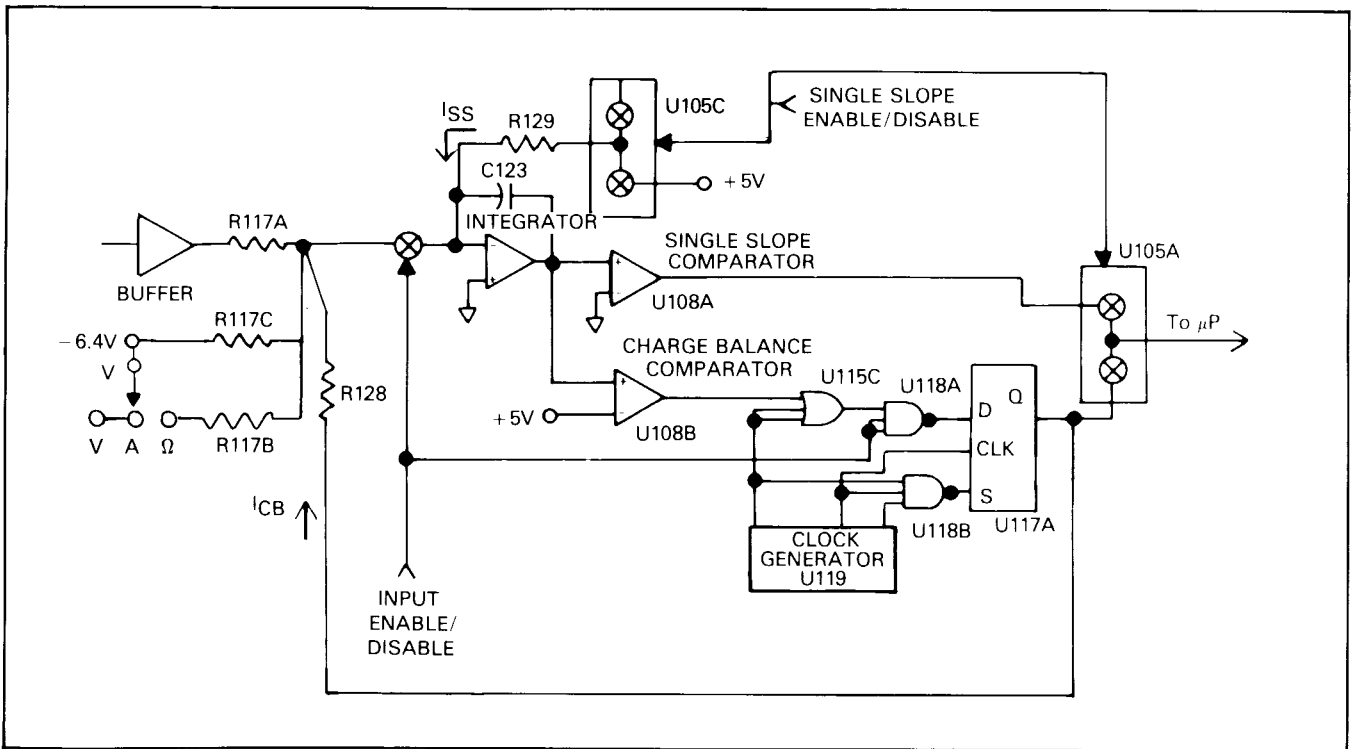

Figure 4-6. A/D Converter

4.4.2 Address Decoding

U123 is used to latch in the address that is on the bus when the address strobe of U124 goes high and presents it to the PROM (U122) during data strobe.

4.4.3 PIA

U114 provides for most of the control of the instrument. It controls all ranging hardware, A/D converter, and data output and input for the IEEE option.

4.4.4 Display Board

The LCD display is driven by a flat pack LCD controller chip U201 and it communicates to the microprocessor through 4 control lines. During power-up the microprocessor configures U201 to drive the triplexed display.

In order to drive the display correctly four voltages are obtained from R134. The clock required by U201 is obtained from U119.

The display board also houses the special function keys; dB, REL, STO/CLR and RCL.

4.5 DIGITAL CALIBRATION

The Model 197 uses digital calibration to eliminate all potentiometers in the instrument to facilitate calibration. The constants that the Model 197 uses are stored in a nonvolatile electrically alterable read only memory (U113), and are read on power-up of the instrument. There is one constant for each range on DCV, ACV and Ω , except for the 750VAC range which uses the constant from the 2V range. On the DCA and ACA functions the 200mV DC and 200mV AC constants are used respectively.

4.6 POWER SUPPLY

Fuse F102 is the LINE FUSE which is internally accessible. S101 is the power on/off switch and S102 selects 115V or 230V operations by placing the transformer primary windings in parallel or series.

T101, the power transformer has two secondary windings; one for the Model 197 and the other for the Model 1972 Analog Output/IEEE option or the Model 1973 IEEE option. The bridge rectifier (CR107) functions as a fullwave rectifier for both the plus and minus supplies. R131 limits current to the 15V zener (VR104) and to the batteries (if installed) for charging. VR104 acts as a pre-regulator to the +10V supply. R132 limits current to the 15V zener VR105. VR105 acts as a pre-regulator to the -9V supply.

4.7 MODEL 1978 BATTERY OPTION

Maximum battery charging rate is achieved when the instrument is connected to line power and the on/off switch is off. Fullwave rectified voltage from CR107 is applied to R102 and

BT101 to charge the batteries. Q101 acts as a current sink if the charging current rises above 150mA. The batteries are of the quick recharge type and will charge in 8 to 10 hours. With the instrument turned on the batteries will trickle charge at approximately 40mA.

With the battery pack installed, the negative supply is generated using a CMOS voltage inverter (U101). The output of the inverter is applied to CR101 and C101 for filtering.

Low battery detection is accomplished by the comparator (U102) and the microprocessor. A voltage level of 11.6V across BT101 signals and end of useful battery life. The trip level for the comparator is set by R103 and R104.

SECTION 5 MAINTENANCE

5.1 INTRODUCTION

This section contains installation, service and calibration information for the Model 197 and Model 1978. Fuse replacement, line voltage selection and troubleshooting procedures are also included in this section.

WARNING

The procedures described in this section are intended for use by qualified service personnel only. Do not perform these procedures unless qualified to do so. Many of the steps covered in this section expose the individual to potentially lethal voltages that could result in personal injury or death if normal safety precautions are not observed.

5.2 TOP COVER REMOVAL/INSTALLATION

The top cover of the Model 197 must be removed in order to service the unit or install the Model 1978 battery pack and/or the Model 1973 or Model 1972 IEEE-488 interface. Proceed as follows:

WARNING

Disconnect the line cord and all other equipment from the Model 197 before removing the top cover.

1. Turn off the power, disconnect the line cord and remove all test leads from the terminals of the Model 197.
2. Turn the unit over and remove the four screws from the bottom of the case.
3. Turn the unit over again and separate the top cover from the rest of the unit.
4. To reinstall the top cover, position the tilt bail properly into the bottom cover; replace top cover and screws.

5.3 BATTERY PACK (Model 1978) INSTALLATION

Refer to Figure 5-1 and perform the following procedure to install the battery pack:

WARNING

Disconnect the line cord and remove all test leads from the terminals of the Model 197.

1. Remove the top cover as explained in paragraph 5.2.
2. Remove the shield.
 - A. Remove the screw that secures the shield to the mother board. The screw is located at the rear of the shield.
 - B. Carefully pull up on either side of the shield.
 - C. Lift the shield out of the Model 197.
3. Position the battery board as shown in Figure 5-1 and secure it to the shield using the two supplied screws. The screws are positioned through the shield into the battery board fasteners.
4. Place the battery pack in the bracket and position on the shield as shown. Route the two screws through the shield into the bracket and tighten.

CAUTION

Do not allow the battery leads to short together or damage to the batteries may occur.

5. Connect the red battery lead to the +RED terminal pin on the battery board. Connect the black battery lead to the -BLK terminal pin on the battery board.

CAUTION

Be careful not to reverse the wires (NOTE: Red to Red and Black to Black).

6. Carefully place the shield (with battery pack) back into the Model 197 so that it seals properly on the two spacers. Replace retaining screw in the shield.

NOTE

The retaining screw on the rear of the shield also serves to connect the shield to circuit LO.

7. Connect the ribbon cable from the battery board to P1009 on the mother board. Make sure pin 1 on the cable connects to pin 1 of P1009. Refer to the detailed drawing of Figure 5-1.

CAUTION

Make a close visual inspection of the connections to ensure that they are properly connected. Otherwise, damage to the instrument may result.

8. Reinstall the top cover as explained in paragraph 5.2.

NOTE

The IEEE Interface options do not run off of battery power.

5.4 LINE VOLTAGE SELECTION

The Model 197 may be operated from either 105V-125V or 210V-250V, 50-60Hz. A special transformer may be installed for 90-110V or 195-235V operation. The instrument was shipped from the factory set for an operating voltage marked on the rear panel. To change the line voltage, proceed as follows:

1. Turn off the Model 197 and disconnect it from line power.
2. Set the LINE VOLTAGE switch on the back of the instrument to correspond to line voltage available. Example: 110VAC is available, set the switch to 105V-125V.

CAUTION

Connect only to the line voltage selected. Application of incorrect voltage can damage the instrument.

3. Plug the power cord into a properly grounded outlet.

WARNING

Ground the instrument through a properly grounded receptacle before operation. Failure to ground the instrument can result in severe injury or death in the event of a short circuit or malfunction.

5.5 FUSE REPLACEMENT

5.5.1 Line Fuse Replacement

The line fuse is located internally in the Model 197. For exact fuse location refer to Figure 5-1. To replace the fuse proceed as follows:

1. Remove the top cover as explained in paragraph 5.2.
2. If the Model 1973 or Model 1972 IEEE-488 interface is installed, it must be removed to gain access to the fuse. The

IEEE board is secured to the mother board by a support post at the rear and connector P1008. To remove, lift the board up until it disengages from the connector and support post.

3. Replace the blown fuse with the following type:
1/8A, 250V, 3AG, Slo-Blo (Keithley Part Number FU-20)

CAUTION

Do not use a fuse with a higher rating than specified or instrument damage may occur. If the instrument persistently blows the fuse, a problem may exist within the instrument. If so, the problem must be corrected before operation may continue.

4. If the IEEE interface was installed, reinstall the interface as follows:

- A. Install the rear standoffs.
- B. Position the interface board above the rear standoffs.

WARNING

Do not push down on J1008. The male connector pins will pass through J1008 and may cause personal injury.

- C. Guide the terminals of P1008 and firmly push down on that end of the board to mate the connectors.
 - D. Push down on the other side of the interface board until it snaps onto the rear most standoff. Make sure the board is properly seated on the other two standoffs.
 - E. Reinstall the modified top cover.
5. Reinstall the top cover as explained in paragraph 5.2.

5.5.2 Current Fuse Replacement

The current fuse protects the 200 μ A through 2000mA ranges from an input current greater than 2A. To replace the current fuse, perform the following steps:

1. Turn off the power, disconnect the power line and remove the test leads.
2. Place the end of a flat blade screwdriver into the slot of the fuse holder on the front panel. Carefully press in and rotate the fuse carrier one-quarter turn counterclockwise. Release pressure, remove the fuse and the fuse carrier from the front panel.
3. Remove the defective fuse and replace it with the following type:
2A, 250V, 3AG, normal blow (Keithley Part Number FU-13) or equivalent

CAUTION

Use only the recommended fuse type. If a fuse with a higher current rating is installed, instrument damage may occur upon overload.

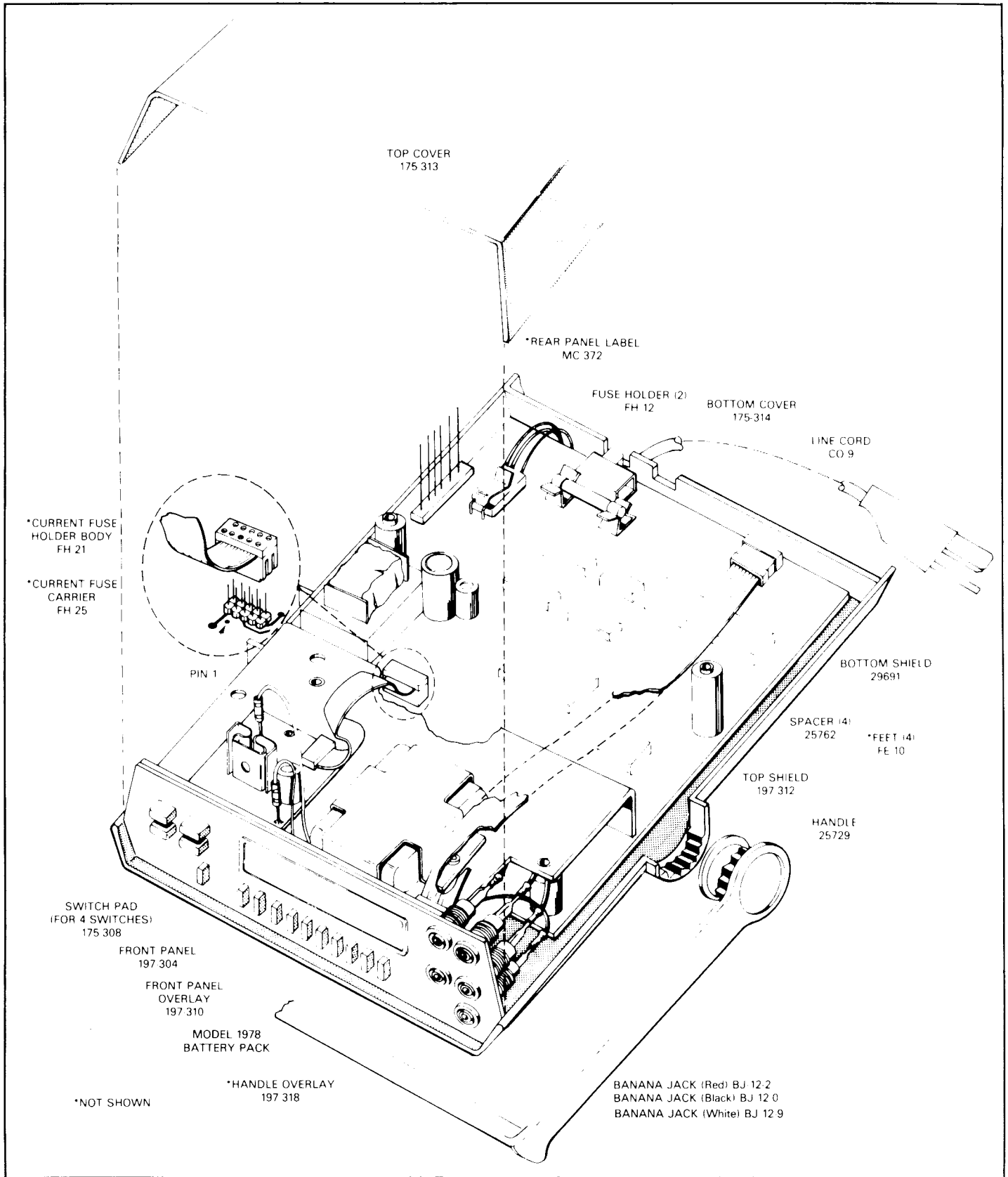

Figure 5-1. Model 197 Miscellaneous Parts



5.6 FRONT PANEL CALIBRATION

Calibration should be performed every 12 months, or if the performance verification procedures in Section 3 show that the Model 197 is out of specification. If any of the calibration procedures in this section cannot be performed properly, refer to the troubleshooting information in this section. If the problem persists, contact your Keithley representative or the factory for further information.

If you have revision C level software in your Model 197, a rear panel external calibration switch has been added to your instrument. When this switch is in ENABLED, it allows you to permanently store calibration constants in NVRAM.

NOTE

For Revision A or Revision B software contact the factory for calibration information. Refer to paragraph 5.7.2 to determine software revision level.

5.6.1 Recommended Calibration Equipment

Calibration may be performed using the equipment listed in Table 5-1. Alternate calibration equipment may be used as long as the equipment's accuracy is at least as good as the specifications listed in Table 5-1.

5.6.2 Environmental Conditions

Calibration should be performed in an ambient temperature of 23°C ±3°C and a relative humidity of less than 70%. If the instrument has been subject to temperature outside of this range, or to higher humidity, allow at least one additional hour for the instrument to stabilize before beginning the calibration procedure.

5.6.3 Calibration Switch

The Model 197 is shipped from the factory with its external calibration switch in the DISABLED position. In this position, calibration constants cannot be stored when entered from the front panel or over the IEEE-488 bus. The switch must be moved to ENABLED to allow calibration constant storage.

The calibration switch is located in the middle of the rear panel. Slide the switch to ENABLED. Plug in the line cord and turn on the instrument. Press in the REL and dB pushbuttons simultaneously until the message "CAL" is displayed. Release the buttons. The unit is now in calibration as indicated by the "C" annunciator.

WARNING

Some procedures require the use of high voltage. Take care to prevent contact with live circuits which could cause electrical shock resulting in injury or death.

Table 5-1. Recommended Calibration Equipment

Description	Required Minimum Specifications	Mfr.	Model No.
DC Voltage Calibrator	200mV, 0.003°% + 0.5µV 2V, 0.003°% + 0.5µV 20V, 0.003°% + 0.5µV 200V, 0.003°% + 0.5µV 1000V, 0.003°%, + 0.5µV (90 day accuracy)	Fluke	5440
AC Voltage Calibrator	200mV, 2V, 20V, 200V and 750V ranges, ±0.05%	Fluke	5200A & 5215A
Resistance Calibrator	190Ω, 50ppm 1.9kΩ, 50ppm 19kΩ, 50ppm 190kΩ, 50ppm 1.9MΩ, 100ppm 19MΩ, 500ppm (90 day accuracy)	Fluke	5450A



NOTE

Calibration may be stopped at any time and if desired, only selected ranges may be calibrated.

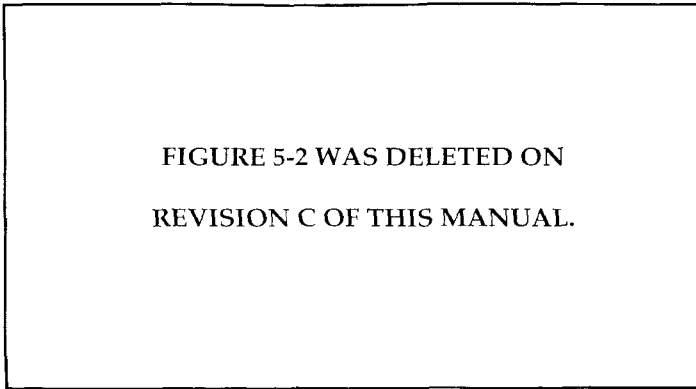

Figure 5-2.

5.6.4 DC Voltage Calibration

Select the DCV function. Connect the DC calibrator to the Model 197 as shown in Figure 5-3.

NOTE

The following procedure must be performed in the exact sequence listed.

1. Press the REL and dB buttons simultaneously until the message "CAL" is displayed. Release the buttons. The Model 197 is now in the calibration mode. The calibration mode is indicated by the "C" annunciator on the front panel display.
2. Select the 200mV range short INPUT HI and LO and press the REL button (REL annunciator is on).
3. Set the calibrator to output +190.000mV.
4. Adjust the display to read 190.000 with the use of the STO/CLR and RCL buttons. The STO/CLR button increments the displayed reading. The RCL button decrements the displayed reading. The longer either button is held in, the faster the displayed reading is modified.
5. Select the next range (2V) and set the calibrator output to +1.90000V.
6. Repeat step 4 to read 1.90000.
7. Reverse the calibrator leads in order to output -1.90000V.
8. Repeat step 4 to read -1.90000.
9. Repeat steps 2 through 4 for the remaining DC voltage ranges listed in Table 5-2.

5.6.5 AC Voltage Calibration

With the Model 197 still in the calibration mode ("C" annunciator on), connect the AC voltage calibrator to the Model

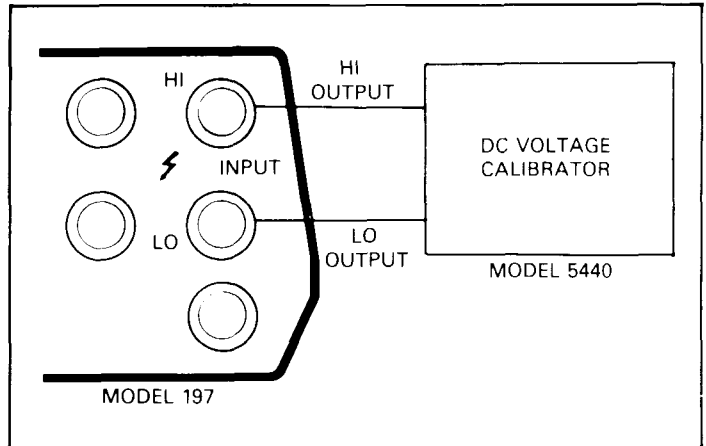

Figure 5-3. DC Voltage Calibration Configuration

Table 5-2. DC Voltage Calibration

Range	Calibrator Voltage	Model 197 Reading
200mV	+190.000mV	190.000mV
2 V	+1.90000 V	1.90000 V
2 V	-1.90000 V	-1.90000 V
20 V	+19.0000 V	19.0000 V
200 V	+190.000 V	190.000 V
1000 V	+1000.00 V	1000.00 V

197 as shown in Figure 5-4. Steps 1-6 must be performed in the exact sequence listed.

1. Select the AC voltage function and the 200mV range.
2. Set the calibrator to output 190.000mV at 500Hz.
3. Adjust the display using the STO/CLR and RCL buttons to read 190.000mV AC.
4. Press the dB button and verify that the dB annunciator is displayed.
5. Set the calibrator to output 19.000mV at 500Hz.
6. Adjust the displayed reading for 19.000mV.
7. Press the REL button and verify that the dB annunciator is off.
8. Repeat steps 2 and 3 for the remaining ranges using Table 5-3 as a guide.
9. Store the new cal constants before proceeding. See paragraph 5.6.8.

5.6.6 Frequency Compensation

The following section is to be used to determine if frequency compensation should be performed on the Model 197, and to perform frequency compensation if necessary. This procedure requires the Model 197 to be warmed up for at least one hour. Note that this section is not to be used to verify that the

Model 197 AC Voltage function is within specifications. If desired refer to Section 3 Performance Verification.

WARNING

Steps 1 through 4 require the use of high voltage. Take care not to come into contact with live circuits that could cause personal injury or death.

1. Select the 750VAC range and set the calibrator to output 500.00V at 500Hz. Press the REL button (REL annunciator turns on).
2. Set the calibrator to output 500.00V at 20kHz. Verify that the reading on the Model 197 is 000.00 ± 150 counts. Press REL (REL annunciator turns off).
3. Set the calibrator to output 100.00V at 500Hz and select the 200VAC range. Press the REL button (REL annunciator turns on).
4. Set the calibrator to output 100.000V at 20kHz. Verify that the reading on the Model 197 is 000.000V ± 200 counts. Press REL (REL annunciator turns off).
5. Set the calibrator to output 10.0000V at 500Hz and select the 20VAC range. Press REL (REL annunciator turns on).
6. Set the calibrator to output 10.0000V at 20kHz. Verify that the reading on the Model 197 is 00.0000 ± 200 counts. Press REL (REL annunciator turns off).

If any of the above verifications are not met by the Model 197, the top cover must be removed and three trimmer capacitors adjusted. The adjustments must be performed within 10 minutes after the top cover is removed so that the circuit components will be close to normal operating temperature. The three trimmer capacitors (C103, C105 and C107) are accessible through the shield. The shield and PC board must be secured to the bottom cover in order to prevent movement. This assembly can be secured with two screws and nuts (not supplied). Route the screws through the bottom cover through the two brown spacers to the shield. Secure the screws with the nuts. Also, use a flat blade, insulated calibration tool for all the adjustments. Perform the following steps in the exact sequence listed.

WARNING

Steps 1 through 4 require the use of high voltage. Take care not to come into contact with live circuits that could cause personal injury or death.

1. Select the 750VAC range and set the calibrator to output 500.00V at 500Hz. Press the REL button (REL annunciator turns on).

2. Set the calibrator to output 500.00V at 20kHz. Adjust C103 for a reading of 000.00 ± 50 counts. Press REL (REL annunciator turns off).
3. Set the calibrator to output 100.00V at 500Hz and select the 200VAC range. Press REL (REL annunciator turns on).
4. Set the calibrator to output 100.00V at 20kHz. Adjust C105 for a reading on the Model 197 of 000.000V ± 50 counts. Press REL (REL annunciator turns off).
5. Set the calibrator to output 10.0000V at 500Hz and select the 20VAC range. Press REL (REL annunciator turns on).
6. Set the calibrator to output 10.0000V at 20kHz. Adjust C107 for a reading on the Model 197 of 00.0000V ± 50 counts.
7. Reinstall the top cover.

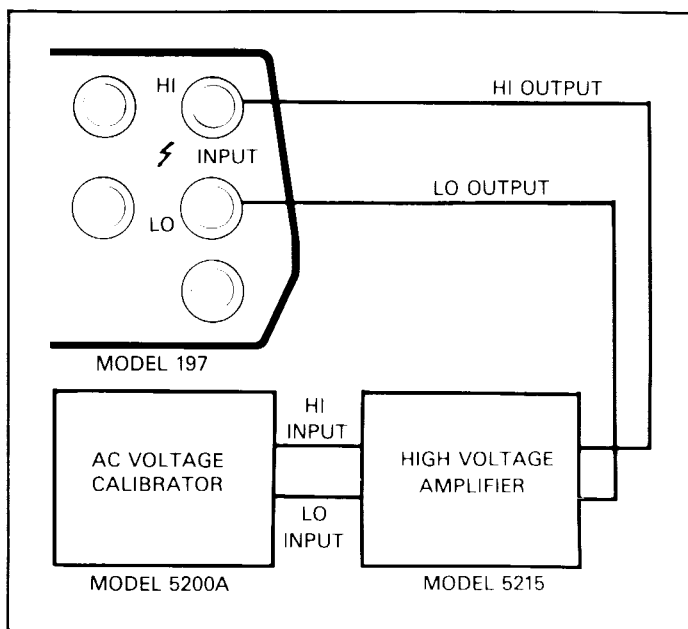

Figure 5-4. AC Voltage Calibration Configuration

Table 5-3. AC Voltage Calibration

Range	Calibrator Voltage	Calibrator Frequency	Model 197 Reading
200mV	190.000mV	500Hz	190.000mV
200mV*	19.000mV	500Hz	19.000mV
2 V	1.90000 V	500Hz	1.90000 V
20 V	19.0000 V	500Hz	19.0000 V
200 V	190.000 V	500Hz	190.000 V

*dB annunciator must be on (indicates two-point calibration).

5.6.7 Resistance Calibration

With the Model 197 in the calibration mode ("C" annunciator on), select the ohms function and connect the calibrator to the Model 197 as shown in Figure 5-5. Four wire resistance measurements need only be done when not using the REL feature. Use the following procedure and refer to Table 5-4 to calibrate the ohms function.

1. Select the 200Ω range and set the resistance calibrator to output zero ohms (short).
2. Press the REL button on the Model 197. The REL annunciator appears on the display and the display reads zero (test lead compensation).
3. Set the calibrator to output 190Ω. Adjust the display using the STO/CLR and RCL buttons for a reading of 190.000Ω. Press REL (REL annunciator turns off).
4. Select the 2kΩ range and set the resistance calibrator to output zero ohms (short). Press REL (REL annunciator turns on).
5. Set the calibrator to output 1.9kΩ. Adjust the display for a reading of 1.90000kΩ.
6. Press the REL button and note that the REL annunciator turns off.
7. Select the 20kΩ range and set the resistance calibrator output zero ohms (short). Press REL (REL annunciator turns on).
8. Set the calibrator to output 19kΩ. Adjust the display for a reading of 19.0000kΩ. Press REL (REL annunciator turns off).
9. Repeat steps 7 and 8 for the 200k, 2M and 20M ranges using Table 5-4 as a guide. For these ranges use the configuration shown in Figure 5-6.

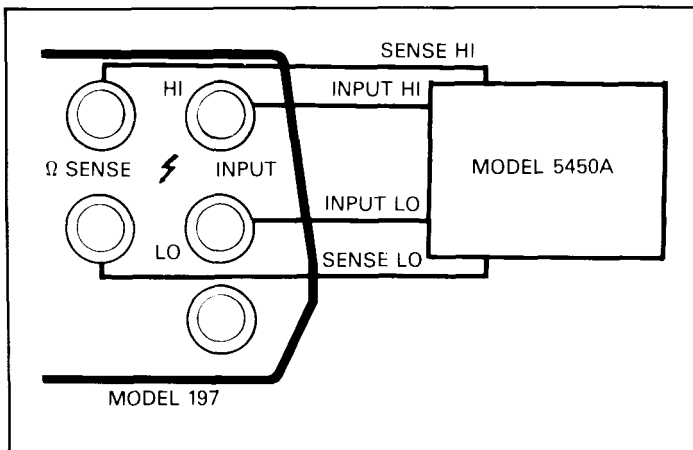

Figure 5-5. 200, 2k and 20k Four Wire Resistance Calibration

NOTE

Four terminal resistance measurements need only be done when not using the REL feature.

5.6.8 Calibration Storage

To store the calibration constants, simultaneously press the REL and dB buttons until the message "Stor" is displayed. If instead the message "out" is displayed, then calibration storage was not enabled and the calibration constants will only be valid until the Model 197 is turned off.

To save calibration constants after "out" appears on the display, slide the calibration switch to ENABLED. Press REL and dB simultaneously until "CAL" appears on the display. Then simultaneously press REL and dB until "Stor" is displayed. The calibration constants are now stored and the Model 197 is ready for normal operation.

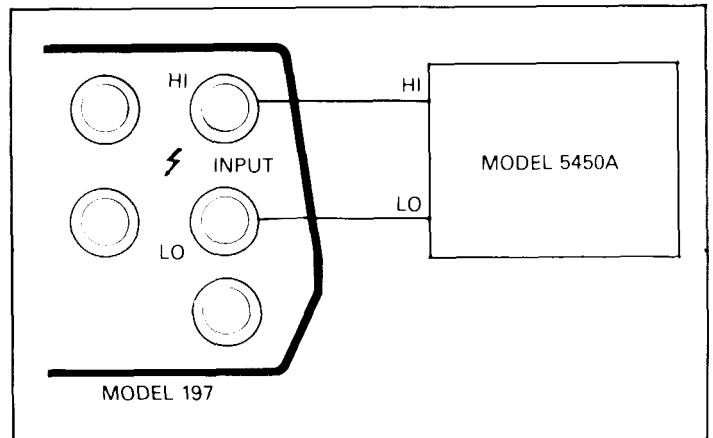

Figure 5-6. 200k, 2M and 20M Two Wire Resistance Calibration

Table 5-4. Resistance Calibration

Range	Calibration Resistance	Model 197 Reading
200 Ω	190 Ω	190.000 Ω
2 kΩ	1.9 kΩ	1.90000 kΩ
20 kΩ	19 kΩ	19.0000 kΩ
200 kΩ	190 kΩ	190.000 kΩ
2MΩ	1.9 MΩ	1.90000 kΩ
20MΩ	19 M	19.0000MΩ

Table 5-5. Recommended Troubleshooting Equipment

Equipment	Use
Five function DMM with 0.1% basic DCV accuracy, 10M input impedance.	Power supply and DC voltage checks; analog signal tracing continuity, logic levels.
Dual-trace, triggered sweep oscilloscope, DC to 50MHz.	Digital and analog waveform checks.
Digital Frequency Counter	Checking clock frequencies.

5.7 TROUBLESHOOTING

The troubleshooting instructions contained in this section are intended for use by qualified personnel having a basic understanding of analog and digital circuitry. The individual should also be experienced at using electronic test equipment as well as standard troubleshooting procedures. The information presented here has been written to assist in isolating a defective circuit or circuit section; isolation of the specific component is left to the technician.

The success or failure in troubleshooting an instrument such as the Model 197 depends not only the skill of the technician, but also relies on accurate, reliable test equipment. Table 5-5 lists the required test equipment and specifications recommended for troubleshooting the Model 197. Other equipment such as logic analyzers, capacitance meters (etc) could also be helpful in difficult situations.

5.7.1 Power Up Sequence

The software revision level of the Model 197 may be displayed upon power-up by running the diagnostic program. The diagnostic program is explained in paragraph 5.7.2.

When the Model 197 is turned on it goes through a power up sequence that is outlined as follows:

1. Reset—All zeroes are briefly displayed before going into the measurement mode. During this display the Model 197 goes through a check of the RAM circuitry, and a check of the NVRAM circuitry.
2. If the RAM circuitry has a problem, the Model 197 locks up with all zeroes. Refer to Table 2-1.
3. If the NVRAM test fails, the following message is displayed:

cErr

4. If no problem is found by the RAM and NVRAM checks, the Model 197 goes into the measurement mode.

If the RAM check reveals a problem, check U121. If the NVRAM check reveals a problem, check U113 and refer to 5.7.2 (NVRAM test).

5.7.2 Self Diagnostic Program

The self diagnostic program is designed to aid the technician in troubleshooting the Model 197. There are several tests that may be performed using the self diagnostic program. These tests (display, software revision level and sequential display test) are run automatically. After this sequence the Model 197 goes into the troubleshooting mode.

To use the self diagnostic program, press and hold in the dB button while turning on the Model 197. The following sequence occurs:

1. All LCD digits and annunciators turn on.
2. The software revision level is then displayed (e.g. A1).
3. The sequential display test runs.
4. The Model 197 goes into the troubleshooting mode.

If the dB button is released, the instrument flags either RAM or NVRAM self test failures, should they occur. If neither RAM nor NVRAM fails, the instrument defaults to the troubleshooting test mode.

RAM Test—If the RAM test fails, the Model 197 locks up with all zeroes displayed. Replacing U112 may correct the problem.

Non-Volatile RAM Test—If the NVRAM test fails, the following message is displayed:

cErr

This is a message indicating that the instrument is not calibrated properly, since calibration constants are stored in NVRAM. The Model 197 remains at this point if the test fails, but operation may be restored for troubleshooting by pressing either the REL, dB or DATA Logger buttons. The flashing "C" annunciator indicates that the unit failed the NVRAM test.

At this point try calibrating the instrument with the constants already entered by simultaneously pressing REL and dB until the CAL message is displayed. Then release the REL and dB buttons. Simultaneously press the REL and dB buttons again until the STOR message is displayed. If the error is corrected, indicating that the NVRAM is probably good, a full calibration is required. If the error persists try replacing the NVRAM chip, U113. Again the Model 197 must be completely recalibrated after the problem is corrected.

Sequential Display Test—Segments and annunciators are sequentially displayed in eight steps. Use Figure 5-7 for segment identification. The steps are as follows:

1. The "a" segments of the digits, the dB and V annunciators are displayed.
2. The "b" segments of the digits are displayed.
3. The "c" segments of the digits are displayed.
4. The "d" segments of the digits are displayed. Also, the m (mA) RCL and RMT annunciators are displayed.
5. The "e" segments of the digits are displayed. Also, the minus sign, REL, M and Ω annunciators are displayed.
6. The "f" segments of the digits are displayed. Also, the AUTO, BAT, m(mV) and c annunciators are displayed.
7. The "g" segments of the digits are displayed. Also, the AC and k annunciators are displayed.
8. The decimal points, most significant digit and the STO, μ and A annunciators are displayed.

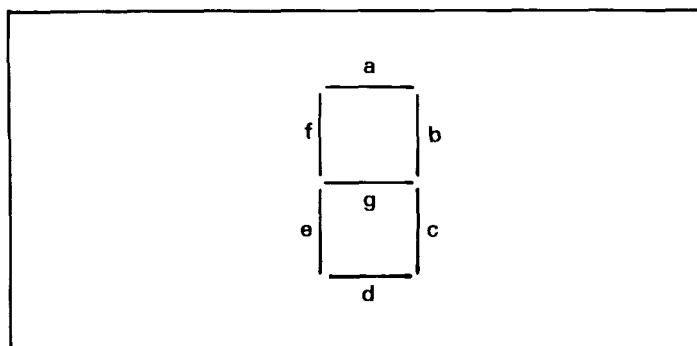

Figure 5-7. Segment Identification

Troubleshooting Test Modes—The troubleshooting mode is designed to switch on various switching FETs, transistors, relays and logic levels to allow signal tracing through the instrument. The first displayed mode reflects the selected function and range. For example; assume that "0u1" is displayed.

In this case,

0 is the test number.

u corresponds to the volts function.

1 corresponds to the 200mV range.

The test number can be changed by pressing in the dB button. Table 5-6 lists test modes for all functions and ranges.

Troubleshooting consists of selecting the desired test mode and using the data found in Table 5-6 to signal trace the circuit.

NOTES:

1. When a different function or range is selected, the dB button must be pressed and held in to update the display with the corresponding test mode.
2. Do not use AUTO when in AC or DC volts.
3. Use AUTO when checking circuitry on the 20M and 200M Ω range (006, 106, 206, 306 and 406).

5.7.3 Power Supply and Battery Pack (Model 1978) Checks

Table 5-7 shows the various checks that can be made to the power supplies of the Model 197 and 1978. In addition to the normal voltage checks, it is a good idea to check the various supplies with an oscilloscope for signs of noise or oscillations.

5.7.4 A/D Converter and Display

Make sure the A/D converter and display are operating properly BEFORE attempting to troubleshoot the signal conditioning circuits. Check these circuits using the information in Table 5-8 and 5-9.

5.7.5 Signal Conditioning

These circuits can be checked by using the diagnostic program (troubleshooting modes). See paragraph 5.7.2. Also, refer to Table 5-6.

Table 5-6. Model 197 Troubleshooting Mode

Function and Range	Test Mode	DC Amp Gain U102	AC Amp Gain U104	Multiplexer FET On	Range Transistor On	Range Control Logic Levels On U			
						PA0	PA1	PA2	PA3
200mVDC	0u1	X10		Q111		0	1	1	0
	1u1	X10		Q112		0	1	0	0
	2u1	X1		Q113		0	0	0	1
	3u1	X1		Q112		0	0	0	0
2VDC	0u2	X1		Q111		0	0	1	0
	1u2	X1		Q112		0	0	0	0
	2u2	X1		Q113		0	0	0	1
	3u2	X1		Q112		0	0	0	0
20VDC	0u3	X1		Q111	Q104, Q105	0	0	1	0
	1u3	X1		Q110	Q104, Q105	1	0	0	0
	2u3	X1		Q113	Q104, Q105	0	0	0	1
	3u3	X1		Q112	Q104, Q105	0	0	0	0
200VDC	0u4	X1		Q111	Q104, Q105, Q106, Q107	0	0	1	0
	1u4	X1		Q110	Q104, Q105, Q106, Q107	1	0	0	0
	2u4	X1		Q113	Q104, Q105, Q106, Q107	0	0	0	1
	3u4	X1		Q112	Q104, Q105, Q106, Q107	0	0	0	0
1kVDC	0u5	X1		Q111	Q104, Q105, Q109, Q108	0	0	1	0
	1u5	X1		Q110	Q104, Q105, Q109, Q108	1	0	0	0
	2u5	X1		Q113	Q104, Q105, Q109, Q108	0	0	0	1
	3u5	X1		Q112	Q104, Q105, Q109, Q108	0	0	0	0
200mVAC	0u1	X1	X5	Q111	Q104—Q107, Q118	0	0	1	0
	1u1	X1	X5	Q112	Q104—Q107, Q118	0	0	0	0
	2u1	X1	X5	Q113	Q104—Q107, Q118	0	0	0	1
	3u1	X1	X5	Q112	Q104—Q107, Q118	0	0	0	0
2VAC	0u2	X1	X1	Q111	Q104—Q107, Q118	0	0	1	0
	1u2	X1	X1	Q112	Q104—Q107, Q118	0	0	0	0
	2u2	X1	X1	Q113	Q104—Q107, Q118	0	0	0	1
	3u3	X1	X1	Q112	Q104—Q107, Q118	0	0	0	0
20VAC	0u3	X1	X1	Q111	Q104, Q105, Q106, Q107	0	0	1	0
	1u3	X1	X1	Q112	Q104, Q105, Q106, Q107	0	0	0	0
	2u3	X1	X1	Q113	Q104, Q105, Q106, Q107	0	0	0	1
	3u3	X1	X1	Q112	Q104, Q105, Q106, Q107	0	0	0	0
200VAC	0u4	X1	X1	Q111	Q104, Q105, Q108, Q109	0	0	1	0
	1u4	X1	X1	Q112	Q104, Q105, Q108, Q109	0	0	0	0
	2u4	X1	X1	Q113	Q104, Q105, Q108, Q109	0	0	0	1
	3u4	X1	X1	Q112	Q104, Q105, Q108, Q109	0	0	0	0
750VAC	0u5	X1	X1	Q111	Q104, Q105	0	0	1	0
	1u5	X1	X1	Q112	Q104, Q105	0	0	0	0
	2u5	X1	X1	Q113	Q104, Q105	0	0	0	1
	3u5	X1	X1	Q112	Q104, Q105	0	0	0	0
DCA All Ranges	0A1-0A6	X10		Q111		0	1	1	0
	1A1-1A6	X10		Q112		0	1	0	0
	2A1-2A6	X1		Q113		0	0	0	1
	3A1-3A6	X1		Q112		0	0	0	0
200Ω	0o1	X10		Q113	Q104, Q105	0	1	0	1
	1o1	X10		Q112	Q104, Q105	0	1	0	0
	2o1	X1		Q111	Q104, Q105	0	0	1	0
	3o1	X1		Q110	Q104, Q105	1	0	0	0

Table 5-6. Model 197 Troubleshooting Mode (Cont.)

Function and Range	Test Mode	DC Amp Gain U102	AC Amp Gain U104	Multiplexer FET On	Range Transistor On	Range Control Logic Levels On U			
						PA0	PA1	PA2	PA3
2k Ω	0o2	X1		Q113	Q104, Q105	0	0	0	1
	1o2	X1		Q112	Q104, Q105	0	0	0	0
	2o2	X1		Q111	Q104, Q105	0	0	1	0
	3o2	X1		Q110	Q104, Q105	1	0	0	0
20k Ω	0o3	X1		Q113	Q104, Q105, Q108, Q109	0	0	0	1
	1o3	X1		Q112	Q104, Q105, Q108, Q109	0	0	0	0
	2o3	X1		Q111	Q104, Q105, Q108, Q109	0	0	1	0
	3o3	X1		Q110	Q104, Q105, Q108, Q109	1	0	0	0
200k Ω	0o4	X1		Q113	Q104, Q105, Q108, Q109	0	0	0	1
	1o4	X1		Q112	Q104, Q105, Q108, Q109	0	0	0	0
	2o4	X1		Q111	Q104, Q105, Q108, Q109	0	0	1	0
	3o4	X1		Q110	Q104, Q105, Q108, Q109	1	0	0	0
2M Ω	0o5	X1		Q113	Q104, Q105	0	0	0	1
	1o5	X1		Q112	Q104, Q105	0	0	0	0
	2o5	X1		Q111	Q104, Q105	0	0	1	0
	3o5	X1		Q110	Q104, Q105	1	0	0	0
20M & 200M (Auto)	0o6	X1		Q113		0	0	0	1
	1o6	X1		Q112		0	0	0	0
	2o6	X1		Q111		0	0	1	0
	3o6	X1		Q113		0	0	0	1
ACA All Ranges	0A1-0A6	X1	X5	Q111		0	0	1	0
	1A1-1A6	X1	X5	Q112		0	0	0	0
	2A1-2A6	X1	X5	Q113		0	0	0	1
	3A1-3A6	X1	X5	Q112		0	0	0	0

5.8 SPECIAL HANDLING OF STATIC-SENSITIVE DEVICES

CMOS devices are designed to operate at very high impedance levels for low power consumption. As a result, any normal static charge that builds up on your person or clothing may be sufficient to destroy these devices if they are not handled properly. Table 5-10 lists all the static sensitive devices in the Model 197. When handling these devices, use the following precautions to avoid damaging them.

1. The devices listed in Table 5-10 should be transported and handled only in containers specially designed to prevent static build up. Typically, these devices will be received in

static-protected containers. The parts should remain there until ready for installation.

2. Remove the devices from their protective containers only at a properly grounded work station. Always ground yourself with a suitable wriststrap.
3. Handle the devices only by the body. Do not touch the pins.
4. Any printed circuit board into which the device is to be inserted must also be grounded to the bench or work station.
5. Use only grounded type solder suckers.
6. Use only a grounded type soldering iron.
7. Once the device is installed on the PC board, the device is adequately protected and normal handling may resume.

Table 5-7. Power Supply and Battery Pack (Model 1978) Checks

Step	Item/Component	Required Condition	Remarks
1	S102	Set to 115V or 230V as required.	S102 is externally accessible from rear panel.
2	F102 Line Fuse	Continuity	
3	Line Cord	Plugged into proper line receptacle; power on.	
4	Power ON/OFF switch pin 6	+ 13V to + 16.5V	+ V power for regulator circuitry.
5	U109 pin 2	+ 6.4 ± 5%	Virtual Reference.
6	U109 pin 3	+ 6.4 ± 5%	Reference Zener.
7	Q126 collector or U116 pin 7	+10V ±10%	+ 10V Supply
8	Power ON/OFF switch pin 12	-15V ± 10%	-V power for regulator circuitry.
9	U107 pin 2	-6.4V ± 10%	Inverting input for U107.
10	U107 pin 3	-6.4V ± 10%	Low noise negative supply reference.
11	Q128 Emmitter	-9.0V, ± 5%	-9V Supply
12	U116 pin 3	+ 5V ± 5%	+ 5V supply reference.
13	U116 pin 2	+ 5V ± 5%	Inverting input for U116.
14	Q126 Emitter	+ 5.0V ± 5%	+ 5V analog supply.
15**	Q123 Emitter or J1009 pin 7	+ 5.0V ± 10%	+ 5V digital supply.
16*	Q101 Base	0.6V while charging. Power switch off.	Current Sink
17*	U101 pin 8	> 10.8V Line cord disconnected, battery pack charged and power on	Voltage Inverter
18*	U102 pin 7	+ 5V with batteries charged.	Voltage Comparator

*Battery option (1978) checks.

**If Q123 is replaced, be sure that the device is properly seated on the mother board so that it will not touch the IEEE board (if installed).

Table 5-8. Display Board Checks

Step	Item/Component	Required Condition	Remarks
1	—	Turn on power; select the 2V range.	
2	P1006, pin 5	+ 3.3V	V _{lcd1}
3	P1006, pin 6	+ 1.66V	V _{lcd2}
4	P1006, pin 7	+ 5V ± 5%	Power to Display
5	P1006, pin 2	81.92kHz	Clock
6	P1006, pin 1	0V to + 5V Pulses	Data From μp.
7	P1006, pin 12	0V to + 5V Pulses	Data From μp.
8	P1006, pin 13	0V to + 5V Pulses	Data From μp.
9	P1006, pin 14	+ 5V to 0V Pulses	Data From μp.
10	LCD	Verify that the LCD is properly positioned.	
11	Connector (P1006)	Check that connector is not reversed.	
12	Strip Connector	Verify that they are positioned properly.	

Table 5-9. A/D Converter/Microcomputer Checks

Step	Item/Component	Required Condition	Remarks
1		Turn on power; select 2VDC range. Short the input.	
2	U124 pin 38	3.276800MHz Clock	Crystal Frequency (Y101) A/D timebase and μ P address strobe. Clocks for U117A. Minimum pulse generator signal. Generates set for U117A. (proper phase of Q4 and Q3 required). Timebase for real time μ P interrupt. S1 input of U118B.
3	U119 pin 10	655.36kHz Clock	
4	U119 pin 6	81.92kHz Clock	
5	U119 pin 5	40.96kHz Clock	
6	U119 pin 7	163.84.kHz Clock	
7	U119 pin 12	1.28kHz Clock	
8	U118 pin 6	+5V to \approx 0V pulse train, 3 μ sec in duration every 22 μ sec. (Set signal to end charge balance pulse.)	
9	U110 pin 6	Integrator Waveform.	Comparator Output (Charge Balance) Charge Balance Current Control. U124 Timer Input Single Slope Control Line Integrator charge Balance Control
10	U108B pin 7	Variable waveform 0V to +5V.	
11	U117 pin 6	Variable pulse train, 0V to +5V.	
12	U105A pin 15	Variable pulse train, 0V to +5V.	
13	U105A pin 10	4msec pulses approximately every 150msec. 0V to +5V.	
14	U117B pin 9	50msec and 100msec pulses positive going.	

Table 5-10. Model 197 Static Sensitive Devices

Circuit Designation	Keithley Part No.
Q104, Q107	TG-139
Q108, Q110	TG-139
Q111, Q112	TG-139
Q113	TG-139
U101	IC-415
U105	IC-283
U107	IC-347
U113	IC-353
U114	LSI-61
U115	IC-143
U117	IC-337
U118	IC-341
U119	IC-348
U120	IC-351
U121	LSI-62
U122	197-800-**
U123	IC-338
U124	LSI-60

SECTION 6

REPLACEABLE PARTS

6.1 INTRODUCTION

This section contains replacement parts information, component location drawings and schematic diagrams for the Model 197 and Model 1978.

6.2 REPLACEABLE PARTS

Parts are listed alpha-numerically in order of the schematic designation. Table 6-1 contains parts list information for the mother board. Table 6-2 contains parts list information for the display board. Parts list information for the Model 1978 Battery Pack is contained in Table 6-3.

6.3 ORDERING INFORMATION

To place an order, or to obtain information concerning replacement parts, contact your Keithley representative or the factory. See the inside front cover for addresses. When ordering include the following information:

1. Instrument Model Number
2. Instrument Serial Number
3. Part Description
4. Circuit Designation (if applicable)
5. Keithley Part Number

If an additional instruction manual is required, order the manual package (Keithley Part Number 197-901-00). The manual package includes an instruction manual and all pertinent addenda.

6.4 FACTORY SERVICE

If the instrument is to be returned to the factory for service, photo copy and complete the service form which follows this section and return it with the instrument.

6.5 SCHEMATIC DIAGRAMS AND COMPONENT LOCATION DRAWINGS

The component location drawings and schematic diagrams, are presented as follows:

Figure 6-2. Model 1978 Battery Pack, Component Location Drawing, Dwg. No. 1978-100.

Figure 6-3. Mother Board, Component Location Drawing, Dwg. No. 197-100.

Figure 6-4. Display Board, Component Location Drawing, Dwg. No. 197-110.

Figure 6-5. Mother Board, Schematic Diagram, Dwg. No. 197-106.

Figure 6-6. Display Board, Schematic Diagram, Dwg. No. 197-116.

Figure 6-7. Model 1978 Battery Pack, Schematic Diagram, Dwg. No. 1978-106.

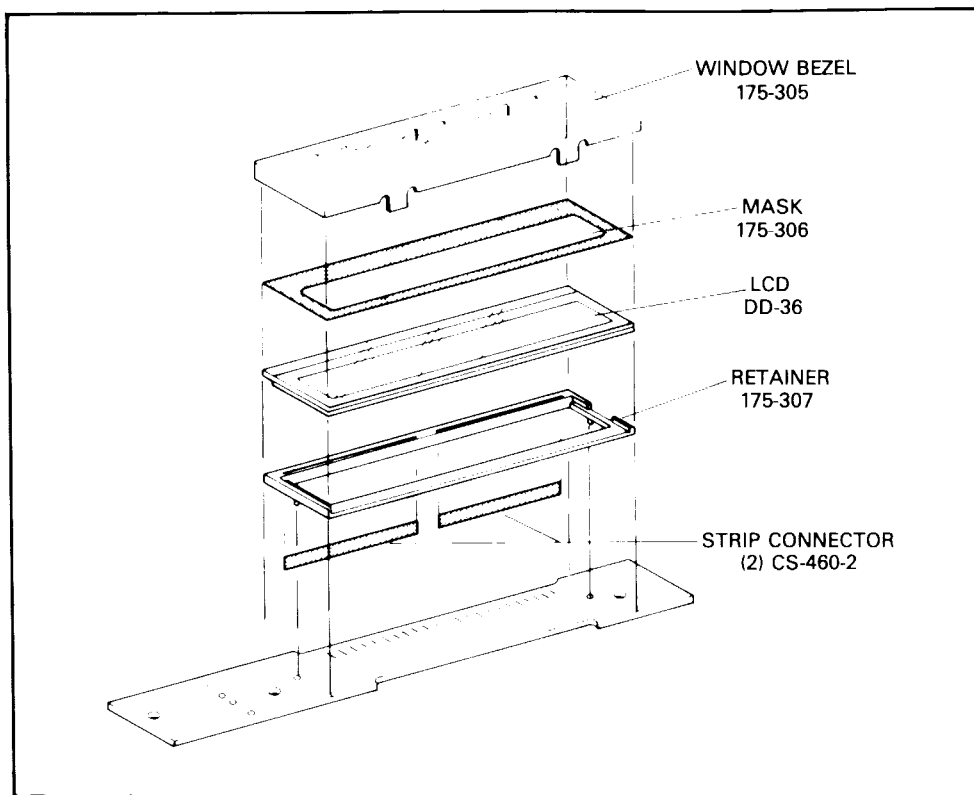

Figure 6-1. Display Assembly Exploded View

Table 6-2. Display Board, Parts List

Schematic Desig.	Description	Location		Keithley Part No.
		Sch	Pcb	
DS-201	5 1/2 Digit Liquid Crystal Display (LCD)	D2	D3	DD-36
P1006	Cable Assembly (14 Conductor)	B4	C4	CA-30-2
U201	LCD Controller/Driver	D3	C4	LSI-59
	Retainer, Strip Connector			175-307
	Strip Connector (2 required)			CS-460-2
	LCD Mask			175-306
	Window Bezel			175-305
	Switch Pad, Conductive Touch			175-308

Table 6-3. Model 1978 Battery Pack, Parts List

Schematic Desig.	Description	Location		Keithley Part No.
		Sch	Pcb	
BT101	Battery Assembly, 12.0V Sealed Rechargeable NiCad	—	B3	BA-40
C101	Capacitor, 250 μ F, 25V, Aluminum Electrolytic	D2	E4	C-314-220
C102	Capacitor, 10 μ F, 25V, Aluminum Electrolytic	D3	C4	C-314-10
CR101	Rectifier, Schottky Barrier, 1N5820	D2	D4	RF-53
P1009	Cable Assembly, 10 Conductor	D2	B1	CA-27-1
R101	Resistor, 4.7 Ω , 10%, 1W, Fixed, Fusible, Wound	E2	C3	R-334-4.7
R102	Resistor, 4.7 Ω , 5%, 1/4W, Composition	E1	C2	R-76-4.7
R103	Resistor, 44.2k, 1%, 1/8W, Metal Film	E3	E3	R-88-44.2k
R104	Resistor, 37.4k, 1%, 1/8W, Metal Film	E3	E4	R-88-37.4k
R105	Resistor, 1.2M, 5%, 1/4W, Composition	D3	E3	R-76-1.2M
Q101	Transistor, NPN, High Voltage (TIP-49)	D3	C2	TG-137
U101*	Voltage Converter, SI7661CJ	D3	D4	IC-340
U102	Voltage Comparator, LM393	D3	E3	IC-343
	Heat Sink used on U101	D3	—	HS-28
	Standoff (Battery Board to Shield)	D3	—	

*Static Sensitive Device

**Figure 6-2. Model 1978 Battery Pack, Component Location
Drawing, Dwg. No. 1978-100**

**Figure 6-3. Mother Board, Component Location Drawing,
Dwg. No. 197-100 (sheet 1 of 2)**

**Figure 6-3. Mother Board, Component Location Drawing,
Dwg. No. 197-100 (sheet 2 of 2)**

**Figure 6-4. Display Board, Component Location Drawing,
Dwg. No. 197-110**

Figure 6-5. Mother Board, Schematic Diagram, Dwg. No. 197-106 (sheet 1 of 2)

Figure 6-5. Mother Board, Schematic Diagram, Dwg. No. 197-106 (sheet 2 of 2)

Figure 6-6. Display Board, Schematic Diagram, Dwg. No. 197-116

**Figure 6-7. Model 1978 Battery Pack, Schematic Diagram,
Dwg. No. 1978-106**



KEITHLEY INSTRUMENTS

Instruments Division, Keithley Instruments, Inc. • 28775 Aurora Road • Cleveland, Ohio 44139 • (216) 248-0400 • Fax: 248-6168

WEST GERMANY: Keithley Instruments GmbH • Heiglhofstr. 5 • Munchen 70 • 089-71002-0 • Telex: 52-12160 • Fax: 089-7100259
GREAT BRITAIN: Keithley Instruments, Ltd. • The Minster • 58, Portman Road • Reading, Berkshire RG 3 1EA • 011 44 734 575 666 • Fax: 011 44 734 596 469
FRANCE: Keithley Instruments SARL • 3 Allee des Garays • B.P. 60 • 91124 Palaiseau/Z.I. • 1-6-0115 155 • Telex: 600 933 • Fax: 1-6-0117726
NETHERLANDS: Keithley Instruments BV • Avelingen West 49 • 4202 MS Gorinchem • P.O. Box 559 • 4200 AN Gorinchem • 01830-35333 • Telex: 24 684 • Fax: 01830-30821
SWITZERLAND: Keithley Instruments SA • Kriesbachstr. 4 • 8600 Dubendorf • 01-821-9444 • Telex: 828 472 • Fax: 0222-315366
AUSTRIA: Keithley Instruments GesmbH • Rosenhugelstrasse 12 • A-1120 Vienna • (0222) 84 65 48 • Telex: 131677 • Fax: (0222) 8403597
ITALY: Keithley Instruments SRL • Viale S. Gimignano 4/A • 20146 Milano • 02-4120360 or 02-4156540 • Fax: 02-4121249

